

# Chapter 1

## Graphs, Equations, and Inequalities

### Section 1.1

1. 0

2.  $|5 - (-3)| = |8| = 8$

3.  $\sqrt{3^2 + 4^2} = \sqrt{25} = 5$

4.  $11^2 + 60^2 = 121 + 3600 = 3721 = 61^2$   
 Since the sum of the squares of two of the sides of the triangle equals the square of the third side, the triangle is a right triangle.

5.  $\frac{1}{2}bh$

6. True

7.  $x$ -coordinate;  $y$ -coordinate

8. quadrants

9. midpoint

10. False; the distance between two points is never negative.

11. False; points that lie in Quadrant IV will have a positive  $x$ -coordinate and a negative  $y$ -coordinate. The point  $(-1, 4)$  lies in Quadrant II.

12. True;  $M = \left( \frac{x_1 + x_2}{2}, \frac{y_1 + y_2}{2} \right)$

13. d

14. c

15. (a) Quadrant II  
 (b)  $x$ -axis  
 (c) Quadrant III  
 (d) Quadrant I  
 (e)  $y$ -axis

(f) Quadrant IV

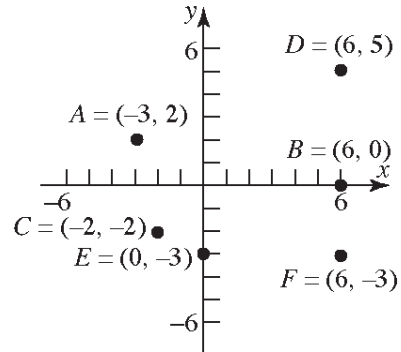

16. (a) Quadrant I  
 (b) Quadrant III  
 (c) Quadrant II  
 (d) Quadrant I  
 (e)  $y$ -axis  
 (f)  $x$ -axis

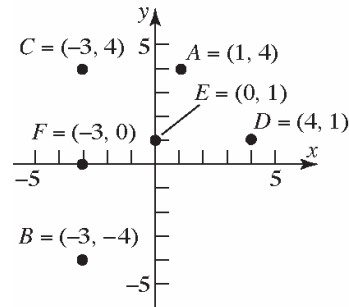

17. The points will be on a vertical line that is two units to the right of the  $y$ -axis.

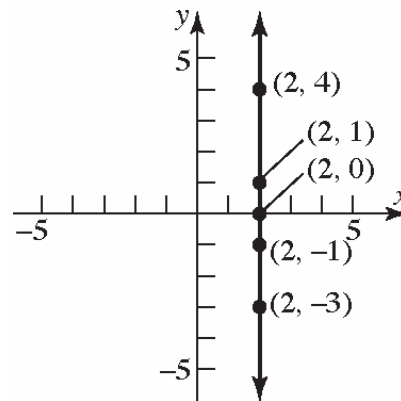

**Chapter 1: Graphs**

18. The points will be on a horizontal line that is three units above the x-axis.

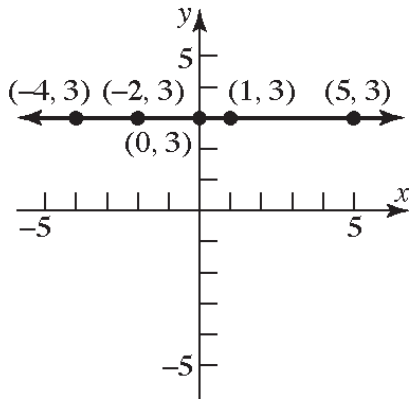

19.  $(-1, 4)$ ; Quadrant II
20.  $(3, 4)$ ; Quadrant I
21.  $(3, 1)$ ; Quadrant I
22.  $(-6, -4)$ ; Quadrant III
23.  $X \text{ min} = -11$   
 $X \text{ max} = 5$   
 $X \text{ scl} = 1$   
 $Y \text{ min} = -3$   
 $Y \text{ max} = 6$   
 $Y \text{ scl} = 1$
24.  $X \text{ min} = -3$   
 $X \text{ max} = 7$   
 $X \text{ scl} = 1$   
 $Y \text{ min} = -4$   
 $Y \text{ max} = 9$   
 $Y \text{ scl} = 1$
25.  $X \text{ min} = -30$   
 $X \text{ max} = 50$   
 $X \text{ scl} = 10$   
 $Y \text{ min} = -90$   
 $Y \text{ max} = 50$   
 $Y \text{ scl} = 10$
26.  $X \text{ min} = -90$   
 $X \text{ max} = 30$   
 $X \text{ scl} = 10$   
 $Y \text{ min} = -50$   
 $Y \text{ max} = 70$   
 $Y \text{ scl} = 10$
27.  $X \text{ min} = -10$   
 $X \text{ max} = 110$   
 $X \text{ scl} = 10$   
 $Y \text{ min} = -10$   
 $Y \text{ max} = 160$   
 $Y \text{ scl} = 10$
28.  $X \text{ min} = -20$   
 $X \text{ max} = 110$   
 $X \text{ scl} = 10$   
 $Y \text{ min} = -10$   
 $Y \text{ max} = 60$   
 $Y \text{ scl} = 10$
29.  $X \text{ min} = -6$   
 $X \text{ max} = 6$   
 $X \text{ scl} = 2$   
 $Y \text{ min} = -4$   
 $Y \text{ max} = 4$   
 $Y \text{ scl} = 2$
30.  $X \text{ min} = -3$   
 $X \text{ max} = 3$   
 $X \text{ scl} = 1$   
 $Y \text{ min} = -2$   
 $Y \text{ max} = 2$   
 $Y \text{ scl} = 1$
31.  $X \text{ min} = -6$   
 $X \text{ max} = 6$   
 $X \text{ scl} = 2$   
 $Y \text{ min} = -1$   
 $Y \text{ max} = 3$   
 $Y \text{ scl} = 1$

**Section 1.1: The Distance and Midpoint Formulas; Graphing Utilities; Introduction to Graphing Equations**

32.  $X \text{ min} = -9$   
 $X \text{ max} = 9$   
 $X \text{ scl} = 3$   
 $Y \text{ min} = -12$   
 $Y \text{ max} = 4$   
 $Y \text{ scl} = 4$

33.  $X \text{ min} = 3$   
 $X \text{ max} = 9$   
 $X \text{ scl} = 1$   
 $Y \text{ min} = 2$   
 $Y \text{ max} = 10$   
 $Y \text{ scl} = 2$

34.  $X \text{ min} = -22$   
 $X \text{ max} = -10$   
 $X \text{ scl} = 2$   
 $Y \text{ min} = 4$   
 $Y \text{ max} = 8$   
 $Y \text{ scl} = 1$

35.  $d(P_1, P_2) = \sqrt{(2-0)^2 + (1-0)^2} = \sqrt{4+1} = \sqrt{5}$

36.  $d(P_1, P_2) = \sqrt{(-2-0)^2 + (1-0)^2} = \sqrt{4+1} = \sqrt{5}$

37.  $d(P_1, P_2) = \sqrt{(-2-1)^2 + (2-1)^2} = \sqrt{9+1} = \sqrt{10}$

38.  $d(P_1, P_2) = \sqrt{(2-(-1))^2 + (2-1)^2}$   
 $= \sqrt{9+1} = \sqrt{10}$

39.  $d(P_1, P_2) = \sqrt{(5-3)^2 + (4-(-4))^2} = \sqrt{2^2 + (8)^2}$   
 $= \sqrt{4+64} = \sqrt{68} = 2\sqrt{17}$

40.  $d(P_1, P_2) = \sqrt{(2-(-1))^2 + (4-0)^2} = \sqrt{(3)^2 + 4^2}$   
 $= \sqrt{9+16} = \sqrt{25} = 5$

41.  $d(P_1, P_2) = \sqrt{(11-(-5))^2 + (9-(-3))^2}$   
 $= \sqrt{16^2 + 12^2} = \sqrt{256+144}$   
 $= \sqrt{400} = 20$

42.  $d(P_1, P_2) = \sqrt{(10-2)^2 + (3-(-3))^2} = \sqrt{8^2 + 6^2}$   
 $= \sqrt{64+36} = \sqrt{100} = 10$

43.  $d(P_1, P_2) = \sqrt{(6-4)^2 + (4-(-3))^2} = \sqrt{2^2 + 7^2}$   
 $= \sqrt{4+49} = \sqrt{53}$

44.  $d(P_1, P_2) = \sqrt{(6-(-4))^2 + (2-(-3))^2}$   
 $= \sqrt{10^2 + 5^2} = \sqrt{100+25}$   
 $= \sqrt{125} = 5\sqrt{5}$

45.  $d(P_1, P_2) = \sqrt{(0-a)^2 + (0-b)^2} = \sqrt{a^2 + b^2}$

46.  $d(P_1, P_2) = \sqrt{(0-a)^2 + (0-a)^2} = \sqrt{a^2 + a^2}$   
 $= \sqrt{2a^2} = \sqrt{2}|a|$

47.  $P_1 = (1,3); P_2 = (5,15)$   
 $d(P_1, P_2) = \sqrt{(5-1)^2 + (15-3)^2}$   
 $= \sqrt{(4)^2 + (12)^2}$   
 $= \sqrt{16+144}$   
 $= \sqrt{160} = 4\sqrt{10}$

48.  $P_1 = (-8, -4); P_2 = (2, 3)$   
 $d(P_1, P_2) = \sqrt{(2-(-8))^2 + (3-(-4))^2}$   
 $= \sqrt{(10)^2 + (7)^2}$   
 $= \sqrt{100+49}$   
 $= \sqrt{149}$

49.  $P_1 = (-4, 6); P_2 = (4, -8)$   
 $d(P_1, P_2) = \sqrt{(4-(-4))^2 + (-8-6)^2}$   
 $= \sqrt{(8)^2 + (-14)^2}$   
 $= \sqrt{64+196}$   
 $= \sqrt{260} = 2\sqrt{65}$

**Chapter 1: Graphs**

50.  $P_1 = (0, 6); P_2 = (3, -8)$

$$\begin{aligned} d(P_1, P_2) &= \sqrt{(3-0)^2 + (-8-6)^2} \\ &= \sqrt{(3)^2 + (-14)^2} \\ &= \sqrt{9+196} \\ &= \sqrt{205} \end{aligned}$$

51.  $A = (-2, 5), B = (1, 3), C = (-1, 0)$

$$\begin{aligned} d(A, B) &= \sqrt{(1-(-2))^2 + (3-5)^2} \\ &= \sqrt{3^2 + (-2)^2} = \sqrt{9+4} \\ &= \sqrt{13} \end{aligned}$$

$$\begin{aligned} d(B, C) &= \sqrt{(-1-1)^2 + (0-3)^2} \\ &= \sqrt{(-2)^2 + (-3)^2} = \sqrt{4+9} \\ &= \sqrt{13} \end{aligned}$$

$$\begin{aligned} d(A, C) &= \sqrt{(-1-(-2))^2 + (0-5)^2} \\ &= \sqrt{1^2 + (-5)^2} = \sqrt{1+25} \\ &= \sqrt{26} \end{aligned}$$

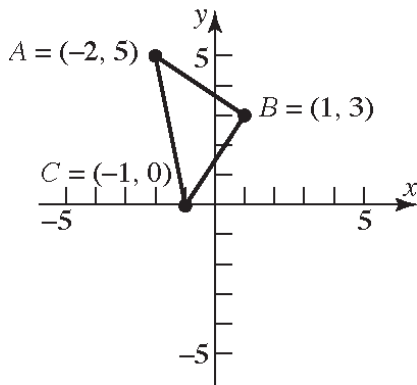

Verifying that  $\triangle ABC$  is a right triangle by the Pythagorean Theorem:

$$[d(A, B)]^2 + [d(B, C)]^2 = [d(A, C)]^2$$

$$(\sqrt{13})^2 + (\sqrt{13})^2 = (\sqrt{26})^2$$

$$13 + 13 = 26$$

$$26 = 26$$

The area of a triangle is  $A = \frac{1}{2} \cdot bh$ . In this

problem,

$$A = \frac{1}{2} \cdot [d(A, B)] \cdot [d(B, C)]$$

$$= \frac{1}{2} \cdot \sqrt{13} \cdot \sqrt{13}$$

$$= \frac{1}{2} \cdot 13$$

$$= \frac{13}{2} \text{ square units}$$

52.  $A = (-2, 5), B = (12, 3), C = (10, -11)$

$$d(A, B) = \sqrt{(12-(-2))^2 + (3-5)^2}$$

$$= \sqrt{14^2 + (-2)^2}$$

$$= \sqrt{196+4} = \sqrt{200}$$

$$= 10\sqrt{2}$$

$$d(B, C) = \sqrt{(10-12)^2 + (-11-3)^2}$$

$$= \sqrt{(-2)^2 + (-14)^2}$$

$$= \sqrt{4+196} = \sqrt{200}$$

$$= 10\sqrt{2}$$

$$d(A, C) = \sqrt{(10-(-2))^2 + (-11-5)^2}$$

$$= \sqrt{12^2 + (-16)^2}$$

$$= \sqrt{144+256} = \sqrt{400}$$

$$= 20$$

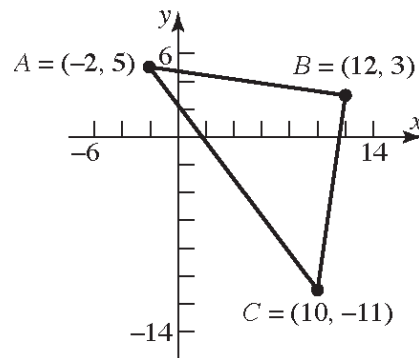

**Section 1.1: The Distance and Midpoint Formulas; Graphing Utilities; Introduction to Graphing Equations**

Verifying that  $\triangle ABC$  is a right triangle by the Pythagorean Theorem:

$$\begin{aligned} [d(A, B)]^2 + [d(B, C)]^2 &= [d(A, C)]^2 \\ (10\sqrt{2})^2 + (10\sqrt{2})^2 &= (20)^2 \\ 200 + 200 &= 400 \\ 400 &= 400 \end{aligned}$$

The area of a triangle is  $A = \frac{1}{2}bh$ . In this problem,

$$\begin{aligned} A &= \frac{1}{2} \cdot [d(A, B)] \cdot [d(B, C)] \\ &= \frac{1}{2} \cdot 10\sqrt{2} \cdot 10\sqrt{2} \\ &= \frac{1}{2} \cdot 100 \cdot 2 \\ &= 100 \text{ square units} \end{aligned}$$

53.  $A = (-5, 3)$ ,  $B = (6, 0)$ ,  $C = (5, 5)$

$$\begin{aligned} d(A, B) &= \sqrt{(6 - (-5))^2 + (0 - 3)^2} \\ &= \sqrt{11^2 + (-3)^2} = \sqrt{121 + 9} \\ &= \sqrt{130} \end{aligned}$$

$$\begin{aligned} d(B, C) &= \sqrt{(5 - 6)^2 + (5 - 0)^2} \\ &= \sqrt{(-1)^2 + 5^2} = \sqrt{1 + 25} \\ &= \sqrt{26} \end{aligned}$$

$$\begin{aligned} d(A, C) &= \sqrt{(5 - (-5))^2 + (5 - 3)^2} \\ &= \sqrt{10^2 + 2^2} = \sqrt{100 + 4} \\ &= \sqrt{104} \\ &= 2\sqrt{26} \end{aligned}$$

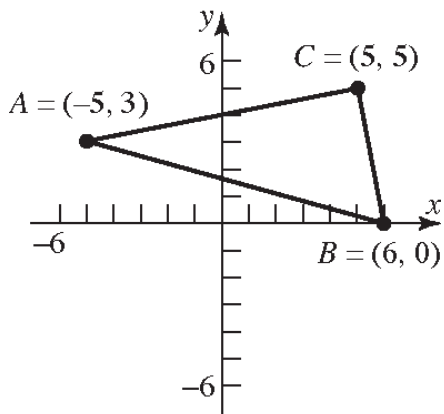

Verifying that  $\triangle ABC$  is a right triangle by the Pythagorean Theorem:

$$\begin{aligned} [d(A, C)]^2 + [d(B, C)]^2 &= [d(A, B)]^2 \\ (\sqrt{104})^2 + (\sqrt{26})^2 &= (\sqrt{130})^2 \\ 104 + 26 &= 130 \\ 130 &= 130 \end{aligned}$$

The area of a triangle is  $A = \frac{1}{2}bh$ . In this problem,

$$\begin{aligned} A &= \frac{1}{2} \cdot [d(A, C)] \cdot [d(B, C)] \\ &= \frac{1}{2} \cdot \sqrt{104} \cdot \sqrt{26} \\ &= \frac{1}{2} \cdot 2\sqrt{26} \cdot \sqrt{26} \\ &= \frac{1}{2} \cdot 2 \cdot 26 \\ &= 26 \text{ square units} \end{aligned}$$

54.  $A = (-6, 3)$ ,  $B = (3, -5)$ ,  $C = (-1, 5)$

$$\begin{aligned} d(A, B) &= \sqrt{(3 - (-6))^2 + (-5 - 3)^2} \\ &= \sqrt{9^2 + (-8)^2} = \sqrt{81 + 64} \\ &= \sqrt{145} \end{aligned}$$

$$\begin{aligned} d(B, C) &= \sqrt{(-1 - 3)^2 + (5 - (-5))^2} \\ &= \sqrt{(-4)^2 + 10^2} = \sqrt{16 + 100} \\ &= \sqrt{116} = 2\sqrt{29} \end{aligned}$$

$$\begin{aligned} d(A, C) &= \sqrt{(-1 - (-6))^2 + (5 - 3)^2} \\ &= \sqrt{5^2 + 2^2} = \sqrt{25 + 4} \\ &= \sqrt{29} \end{aligned}$$

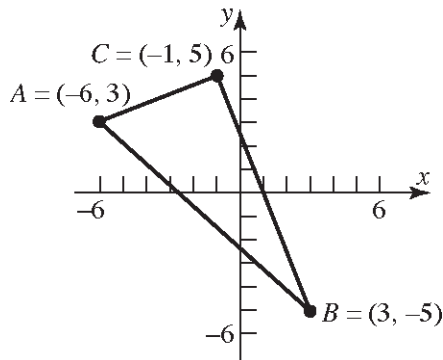

Verifying that  $\triangle ABC$  is a right triangle by the Pythagorean Theorem:

**Chapter 1: Graphs**

$$[d(A,C)]^2 + [d(B,C)]^2 = [d(A,B)]^2$$

$$(\sqrt{29})^2 + (\sqrt{116})^2 = (\sqrt{145})^2$$

$$29 + 116 = 145$$

$$145 = 145$$

The area of a triangle is  $A = \frac{1}{2}bh$ . In this problem,

$$A = \frac{1}{2} \cdot [d(A,C)] \cdot [d(B,C)]$$

$$= \frac{1}{2} \cdot \sqrt{29} \cdot \sqrt{116}$$

$$= \frac{1}{2} \cdot \sqrt{29} \cdot 2\sqrt{29}$$

$$= \frac{1}{2} \cdot 2 \cdot 29$$

$$= 29 \text{ square units}$$

55.  $A = (4, -3)$ ,  $B = (0, -3)$ ,  $C = (4, 2)$

$$d(A,B) = \sqrt{(0-4)^2 + (-3-(-3))^2}$$

$$= \sqrt{(-4)^2 + 0^2} = \sqrt{16+0}$$

$$= \sqrt{16}$$

$$= 4$$

$$d(B,C) = \sqrt{(4-0)^2 + (2-(-3))^2}$$

$$= \sqrt{4^2 + 5^2} = \sqrt{16+25}$$

$$= \sqrt{41}$$

$$d(A,C) = \sqrt{(4-4)^2 + (2-(-3))^2}$$

$$= \sqrt{0^2 + 5^2} = \sqrt{0+25}$$

$$= \sqrt{25}$$

$$= 5$$

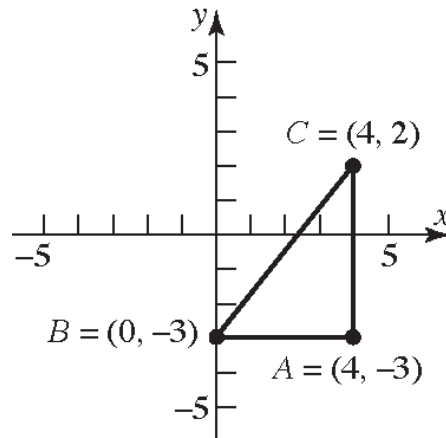

Verifying that  $\triangle ABC$  is a right triangle by the Pythagorean Theorem:

$$[d(A,B)]^2 + [d(A,C)]^2 = [d(B,C)]^2$$

$$4^2 + 5^2 = (\sqrt{41})^2$$

$$16 + 25 = 41$$

$$41 = 41$$

The area of a triangle is  $A = \frac{1}{2}bh$ . In this problem,

$$A = \frac{1}{2} \cdot [d(A,B)] \cdot [d(A,C)]$$

$$= \frac{1}{2} \cdot 4 \cdot 5$$

$$= 10 \text{ square units}$$

**Section 1.1: The Distance and Midpoint Formulas; Graphing Utilities; Introduction to Graphing Equations**

56.  $A = (4, -3), B = (4, 1), C = (2, 1)$

$$\begin{aligned} d(A, B) &= \sqrt{(4-4)^2 + (1-(-3))^2} \\ &= \sqrt{0^2 + 4^2} \\ &= \sqrt{0+16} \\ &= \sqrt{16} \\ &= 4 \end{aligned}$$

$$\begin{aligned} d(B, C) &= \sqrt{(2-4)^2 + (1-1)^2} \\ &= \sqrt{(-2)^2 + 0^2} = \sqrt{4+0} \\ &= \sqrt{4} \\ &= 2 \end{aligned}$$

$$\begin{aligned} d(A, C) &= \sqrt{(2-4)^2 + (1-(-3))^2} \\ &= \sqrt{(-2)^2 + 4^2} = \sqrt{4+16} \\ &= \sqrt{20} \\ &= 2\sqrt{5} \end{aligned}$$

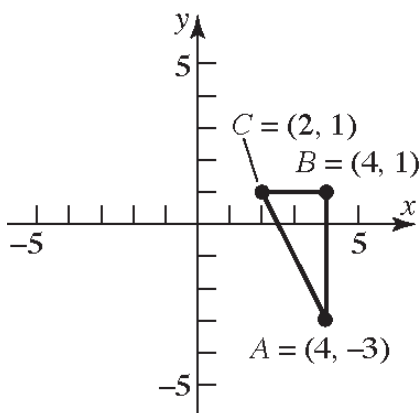

Verifying that  $\triangle ABC$  is a right triangle by the Pythagorean Theorem:

$$[d(A, B)]^2 + [d(B, C)]^2 = [d(A, C)]^2$$

$$4^2 + 2^2 = (2\sqrt{5})^2$$

$$16 + 4 = 20$$

$$20 = 20$$

The area of a triangle is  $A = \frac{1}{2}bh$ . In this problem,

$$\begin{aligned} A &= \frac{1}{2} \cdot [d(A, B)] \cdot [d(B, C)] \\ &= \frac{1}{2} \cdot 4 \cdot 2 \\ &= 4 \text{ square units} \end{aligned}$$

57. The coordinates of the midpoint are:

$$\begin{aligned} (x, y) &= \left( \frac{x_1 + x_2}{2}, \frac{y_1 + y_2}{2} \right) \\ &= \left( \frac{3+5}{2}, \frac{-4+4}{2} \right) \\ &= \left( \frac{8}{2}, \frac{0}{2} \right) \\ &= (4, 0) \end{aligned}$$

58. The coordinates of the midpoint are:

$$\begin{aligned} (x, y) &= \left( \frac{x_1 + x_2}{2}, \frac{y_1 + y_2}{2} \right) \\ &= \left( \frac{-2+2}{2}, \frac{0+4}{2} \right) \\ &= \left( \frac{0}{2}, \frac{4}{2} \right) \\ &= (0, 2) \end{aligned}$$

59. The coordinates of the midpoint are:

$$\begin{aligned} (x, y) &= \left( \frac{x_1 + x_2}{2}, \frac{y_1 + y_2}{2} \right) \\ &= \left( \frac{-5+11}{2}, \frac{-3+9}{2} \right) \\ &= \left( \frac{6}{2}, \frac{6}{2} \right) \\ &= (3, 3) \end{aligned}$$

60. The coordinates of the midpoint are:

$$\begin{aligned} (x, y) &= \left( \frac{x_1 + x_2}{2}, \frac{y_1 + y_2}{2} \right) \\ &= \left( \frac{2+10}{2}, \frac{-3+3}{2} \right) \\ &= \left( \frac{12}{2}, \frac{0}{2} \right) \\ &= (6, 0) \end{aligned}$$

**Chapter 1: Graphs**

- 61.** The coordinates of the midpoint

$$\begin{aligned} \text{are } (x, y) &= \left( \frac{x_1 + x_2}{2}, \frac{y_1 + y_2}{2} \right) \\ &= \left( \frac{4+6}{2}, \frac{-3+1}{2} \right) \\ &= \left( \frac{10}{2}, \frac{-2}{2} \right) \\ &= (5, -1) \end{aligned}$$

- 62.** The coordinates of the midpoint are:

$$\begin{aligned} (x, y) &= \left( \frac{x_1 + x_2}{2}, \frac{y_1 + y_2}{2} \right) \\ &= \left( \frac{-4+2}{2}, \frac{-3+2}{2} \right) \\ &= \left( \frac{-2}{2}, \frac{-1}{2} \right) \\ &= \left( -1, -\frac{1}{2} \right) \end{aligned}$$

- 63.** The coordinates of the midpoint are:

$$\begin{aligned} (x, y) &= \left( \frac{x_1 + x_2}{2}, \frac{y_1 + y_2}{2} \right) \\ &= \left( \frac{a+0}{2}, \frac{b+0}{2} \right) \\ &= \left( \frac{a}{2}, \frac{b}{2} \right) \end{aligned}$$

- 64.** The coordinates of the midpoint are:

$$\begin{aligned} (x, y) &= \left( \frac{x_1 + x_2}{2}, \frac{y_1 + y_2}{2} \right) \\ &= \left( \frac{a+0}{2}, \frac{a+0}{2} \right) \\ &= \left( \frac{a}{2}, \frac{a}{2} \right) \end{aligned}$$

- 65.**  $y = x^4 - \sqrt{x}$

$$\begin{aligned} 0 &= 0^4 - \sqrt{0} & 1 &= 1^4 - \sqrt{1} & 0 &= (-1)^4 - \sqrt{-1} \\ 0 &= 0 & 1 &\neq 0 & 0 &\neq 1 - \sqrt{-1} \end{aligned}$$

(0, 0) is on the graph of the equation.

- 66.**  $y = x^3 - 2\sqrt{x}$

$$\begin{aligned} 0 &= 0^3 - 2\sqrt{0} & 1 &= 1^3 - 2\sqrt{1} & -1 &= 1^3 - 2\sqrt{1} \\ 0 &= 0 & 1 &\neq -1 & -1 &= -1 \end{aligned}$$

(0, 0) and (1, -1) are on the graph of the equation.

- 67.**  $y^2 = x^2 + 9$

$$\begin{aligned} 3^2 &= 0^2 + 9 & 0^2 &= 3^2 + 9 & 0^2 &= (-3)^2 + 9 \\ 9 &= 9 & 0 &\neq 18 & 0 &\neq 18 \end{aligned}$$

(0, 3) is on the graph of the equation.

- 68.**  $y^3 = x + 1$

$$\begin{aligned} 2^3 &= 1+1 & 1^3 &= 0+1 & 0^3 &= -1+1 \\ 8 &\neq 2 & 1 &= 1 & 0 &= 0 \end{aligned}$$

(0, 1) and (-1, 0) are on the graph of the equation.

- 69.**  $x^2 + y^2 = 4$

$$\begin{aligned} 0^2 + 2^2 &= 4 & (-2)^2 + 2^2 &= 4 & \sqrt{2}^2 + \sqrt{2}^2 &= 4 \\ 4 &= 4 & 8 &\neq 4 & 4 &= 4 \end{aligned}$$

(0, 2) and  $(\sqrt{2}, \sqrt{2})$  are on the graph of the equation.

- 70.**  $x^2 + 4y^2 = 4$

$$\begin{aligned} 0^2 + 4 \cdot 1^2 &= 4 & 2^2 + 4 \cdot 0^2 &= 4 & 2^2 + 4 \left(\frac{1}{2}\right)^2 &= 4 \\ 4 &= 4 & 4 &= 4 & 5 &\neq 4 \end{aligned}$$

(0, 1) and (2, 0) are on the graph of the equation.

- 71.** (-1, 0), (1, 0)

- 72.** (0, 1)

- 73.**  $\left(-\frac{\pi}{2}, 0\right), \left(\frac{\pi}{2}, 0\right), (0, 1)$

- 74.** (-2, 0), (2, 0), (0, -3)

- 75.** (1, 0), (0, 2), (0, -2)

- 76.** (2, 0), (0, 2), (-2, 0), (0, -2)

- 77.** (-4, 0), (-1, 0), (4, 0), (0, -3)

- 78.** (-2, 0), (2, 0), (0, 3)



**Section 1.1: The Distance and Midpoint Formulas; Graphing Utilities; Introduction to Graphing Equations**

79.  $y = x + 2$

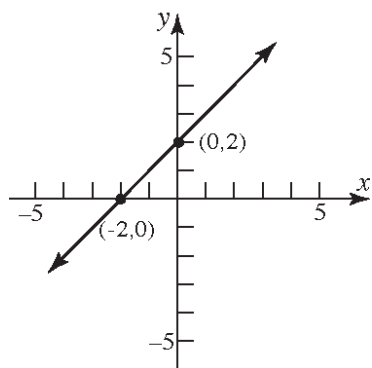

82.  $y = 3x - 9$

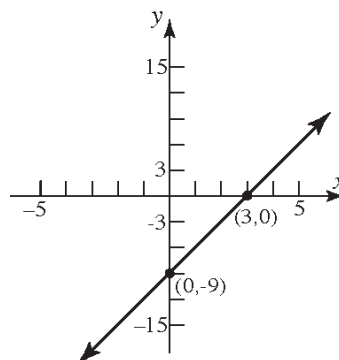

80.  $y = x - 6$

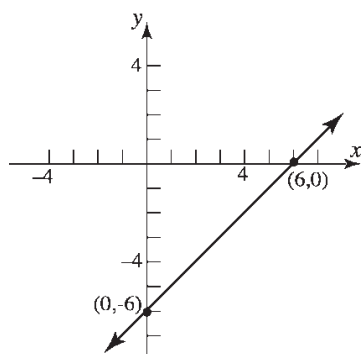

83.  $y = x^2 - 1$

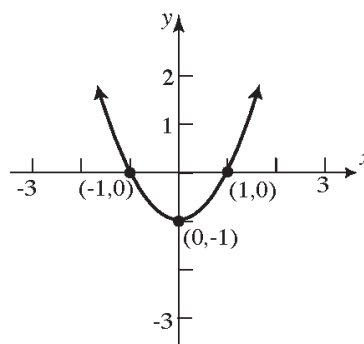

81.  $y = 2x + 8$

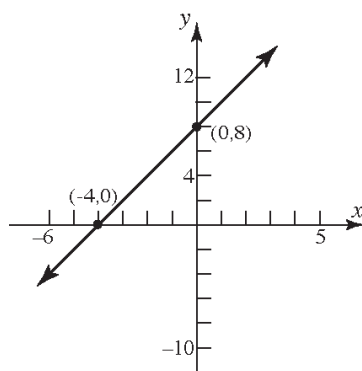

84.  $y = x^2 - 9$

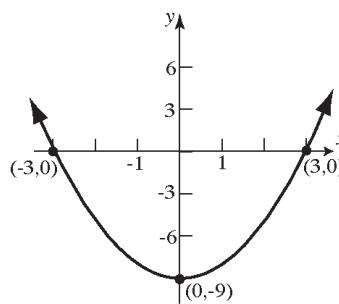

**Chapter 1: Graphs**

85.  $y = -x^2 + 4$

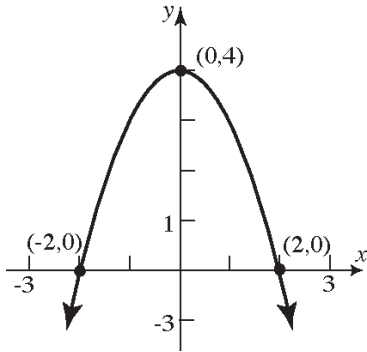

89.  $9x^2 + 4y = 36$

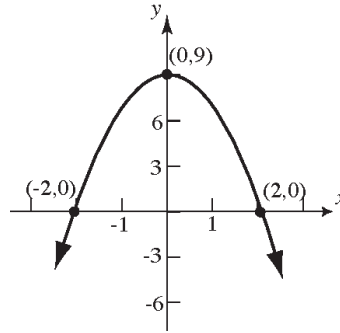

86.  $y = -x^2 + 1$

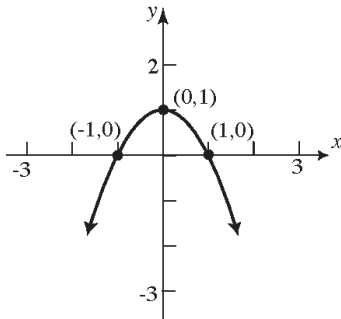

90.  $4x^2 + y = 4$

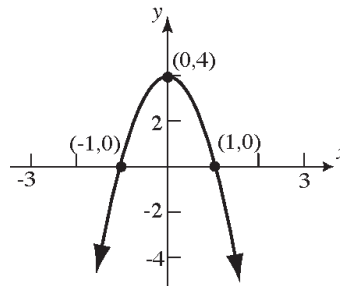

87.  $2x + 3y = 6$

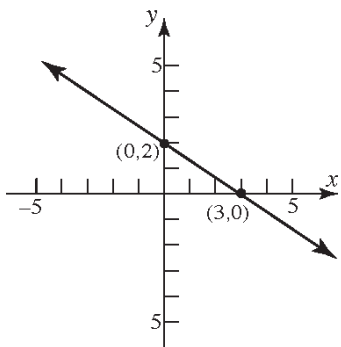

91.  $y = 2x - 13$

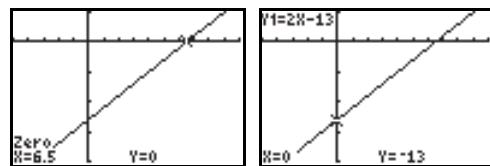
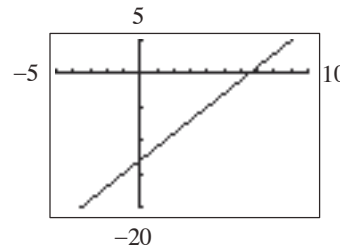

The x-intercept is  $x = 6.5$  and the y-intercept is  $y = -13$ .

88.  $5x + 2y = 10$

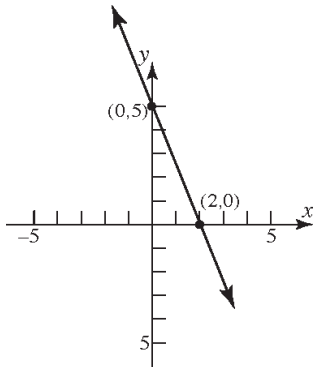

**Section 1.1: The Distance and Midpoint Formulas; Graphing Utilities; Introduction to Graphing Equations**

92.  $y = -3x + 14$

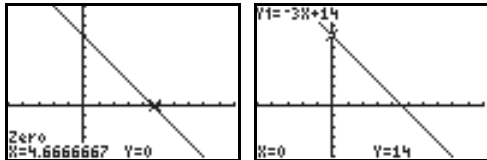
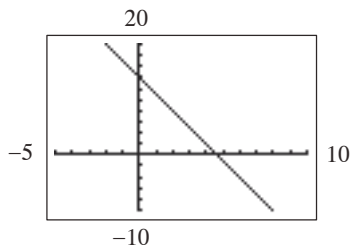

The x-intercept is  $x = 4.67$  and the y-intercept is  $y = 14$ .

93.  $y = 2x^2 - 15$

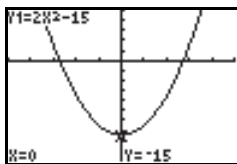
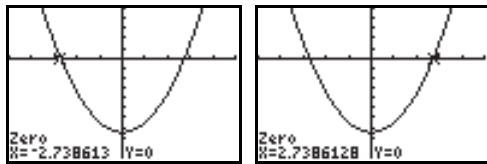
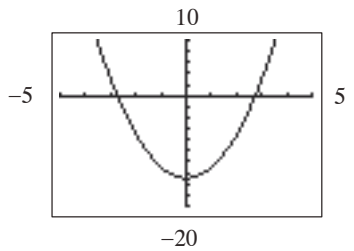

The x-intercepts are  $x = -2.74$  and  $x = 2.74$ .  
The y-intercept is  $y = -15$ .

94.  $y = -3x^2 + 19$

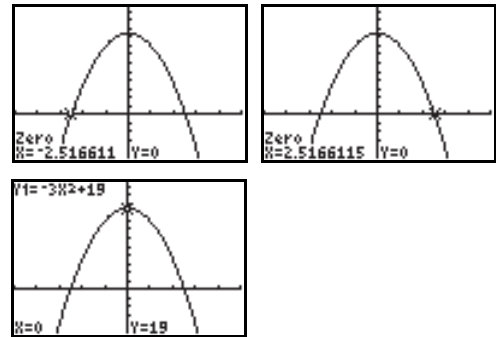
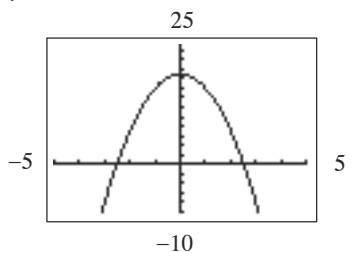

The x-intercepts are  $x = -2.52$  and  $x = 2.52$ .  
The y-intercept is  $y = 19$ .

95.  $3x - 2y = 43$  or  $y = \frac{3x - 43}{2}$

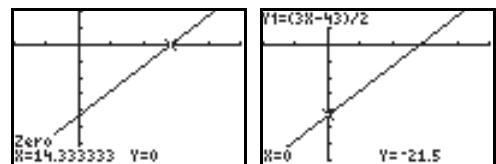
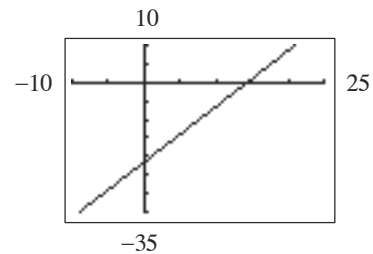

The x-intercept is  $x = 14.33$  and the y-intercept is  $y = -21.5$ .

96.  $4x + 5y = 82$  or  $y = \frac{-4x + 82}{5}$

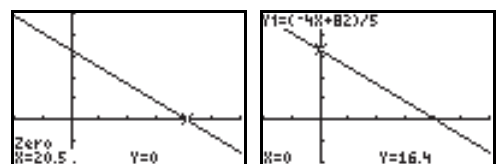
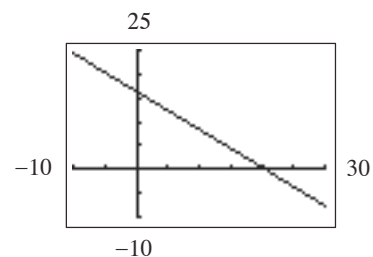

The x-intercept is  $x = 20.5$  and the y-intercept is  $y = 16.4$ .

**Chapter 1: Graphs**

97.  $5x^2 + 3y = 37$  or  $y = \frac{-5x^2 + 37}{3}$

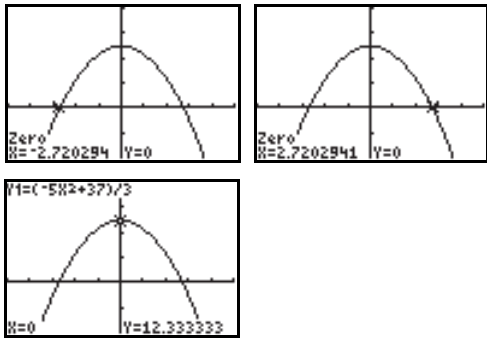
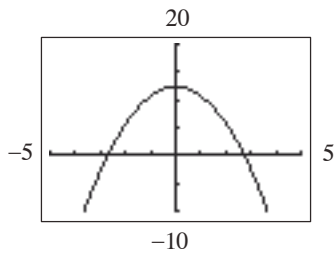

The x-intercepts are  $x = -2.72$  and  $x = 2.72$ .  
The y-intercept is  $y = 12.33$ .

98.  $2x^2 - 3y = 35$  or  $y = \frac{2x^2 - 35}{3}$

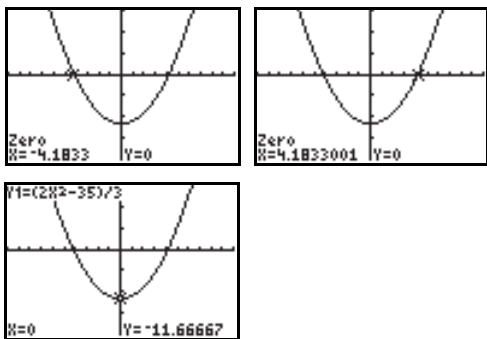
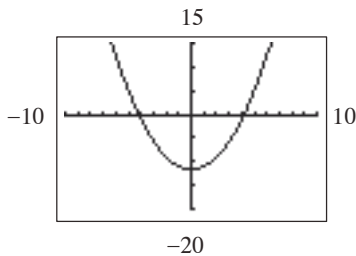

The x-intercepts are  $x = -4.18$  and  $x = 4.18$ .  
The y-intercept is  $y = -11.67$ .

99. If  $(2, 5)$  is shifted 3 units right then the x coordinate would be  $2 + 3$ . If it is shifted 2 units down then the y-coordinate would be  $5 + (-2)$ .

Thus the new point would be  $(2 + 3, 5 + (-2)) = (5, 3)$ .

100. If  $(-1, 6)$  is shifted 2 units left then the x coordinate would be  $-1 + (-2)$ . If it is shifted 4 units up then the y-coordinate would be  $6 + 4$ . Thus the new point would be  $(-1 + (-2), 6 + 4) = (-3, 10)$ .

101. The midpoint of AB is:  $D = \left(\frac{0+6}{2}, \frac{0+0}{2}\right) = (3, 0)$

The midpoint of AC is:  $E = \left(\frac{0+4}{2}, \frac{0+4}{2}\right) = (2, 2)$

The midpoint of BC is:  $F = \left(\frac{6+4}{2}, \frac{0+4}{2}\right) = (5, 2)$

$$d(C, D) = \sqrt{(0-4)^2 + (3-4)^2} = \sqrt{(-4)^2 + (-1)^2} = \sqrt{16+1} = \sqrt{17}$$

$$d(B, E) = \sqrt{(2-6)^2 + (2-0)^2} = \sqrt{(-4)^2 + 2^2} = \sqrt{16+4} = \sqrt{20} = 2\sqrt{5}$$

$$d(A, F) = \sqrt{(2-0)^2 + (5-0)^2} = \sqrt{2^2 + 5^2} = \sqrt{4+25} = \sqrt{29}$$

**Section 1.1: The Distance and Midpoint Formulas; Graphing Utilities; Introduction to Graphing Equations**

- 102.** Let  $P_1 = (0, 0)$ ,  $P_2 = (0, 4)$ ,  $P = (x, y)$

$$\begin{aligned} d(P_1, P_2) &= \sqrt{(0-0)^2 + (4-0)^2} \\ &= \sqrt{16} = 4 \end{aligned}$$

$$\begin{aligned} d(P_1, P) &= \sqrt{(x-0)^2 + (y-0)^2} \\ &= \sqrt{x^2 + y^2} = 4 \\ &\rightarrow x^2 + y^2 = 16 \end{aligned}$$

$$\begin{aligned} d(P_2, P) &= \sqrt{(x-0)^2 + (y-4)^2} \\ &= \sqrt{x^2 + (y-4)^2} = 4 \\ &\rightarrow x^2 + (y-4)^2 = 16 \end{aligned}$$

Therefore,

$$y^2 = (y-4)^2$$

$$y^2 = y^2 - 8y + 16$$

$$8y = 16$$

$$y = 2$$

which gives

$$x^2 + 2^2 = 16$$

$$x^2 = 12$$

$$x = \pm 2\sqrt{3}$$

Two triangles are possible. The third vertex is  $(-2\sqrt{3}, 2)$  or  $(2\sqrt{3}, 2)$ .

**103.**  $d(P_1, P_2) = \sqrt{(-4-2)^2 + (1-1)^2}$   
 $= \sqrt{(-6)^2 + 0^2}$   
 $= \sqrt{36}$   
 $= 6$

$$\begin{aligned} d(P_2, P_3) &= \sqrt{(-4-(-4))^2 + (-3-1)^2} \\ &= \sqrt{0^2 + (-4)^2} \\ &= \sqrt{16} \\ &= 4 \end{aligned}$$

$$\begin{aligned} d(P_1, P_3) &= \sqrt{(-4-2)^2 + (-3-1)^2} \\ &= \sqrt{(-6)^2 + (-4)^2} \\ &= \sqrt{36+16} \\ &= \sqrt{52} \\ &= 2\sqrt{13} \end{aligned}$$

Since  $[d(P_1, P_2)]^2 + [d(P_2, P_3)]^2 = [d(P_1, P_3)]^2$ , the triangle is a right triangle.

**104.**  $d(P_1, P_2) = \sqrt{(6-(-1))^2 + (2-4)^2}$   
 $= \sqrt{7^2 + (-2)^2}$   
 $= \sqrt{49+4}$   
 $= \sqrt{53}$

$$\begin{aligned} d(P_2, P_3) &= \sqrt{(4-6)^2 + (-5-2)^2} \\ &= \sqrt{(-2)^2 + (-7)^2} \\ &= \sqrt{4+49} \\ &= \sqrt{53} \end{aligned}$$

$$\begin{aligned} d(P_1, P_3) &= \sqrt{(4-(-1))^2 + (-5-4)^2} \\ &= \sqrt{5^2 + (-9)^2} \\ &= \sqrt{25+81} \\ &= \sqrt{106} \end{aligned}$$

Since  $[d(P_1, P_2)]^2 + [d(P_2, P_3)]^2 = [d(P_1, P_3)]^2$ , the triangle is a right triangle.

Since  $d(P_1, P_2) = d(P_2, P_3)$ , the triangle is isosceles.

Therefore, the triangle is an isosceles right triangle.

**105.**  $d(P_1, P_2) = \sqrt{(0-(-2))^2 + (7-(-1))^2}$   
 $= \sqrt{2^2 + 8^2} = \sqrt{4+64} = \sqrt{68}$   
 $= 2\sqrt{17}$

$$\begin{aligned} d(P_2, P_3) &= \sqrt{(3-0)^2 + (2-7)^2} \\ &= \sqrt{3^2 + (-5)^2} = \sqrt{9+25} \\ &= \sqrt{34} \end{aligned}$$

$$\begin{aligned} d(P_1, P_3) &= \sqrt{(3-(-2))^2 + (2-(-1))^2} \\ &= \sqrt{5^2 + 3^2} = \sqrt{25+9} \\ &= \sqrt{34} \end{aligned}$$

Since  $d(P_2, P_3) = d(P_1, P_3)$ , the triangle is isosceles.

Since  $[d(P_1, P_3)]^2 + [d(P_2, P_3)]^2 = [d(P_1, P_2)]^2$ , the triangle is also a right triangle.

Therefore, the triangle is an isosceles right triangle.

**Chapter 1: Graphs**

$$\begin{aligned}
 106. \quad d(P_1, P_2) &= \sqrt{(-4-7)^2 + (0-2)^2} \\
 &= \sqrt{(-11)^2 + (-2)^2} \\
 &= \sqrt{121+4} = \sqrt{125} \\
 &= 5\sqrt{5} \\
 d(P_2, P_3) &= \sqrt{(4-(-4))^2 + (6-0)^2} \\
 &= \sqrt{8^2 + 6^2} = \sqrt{64+36} \\
 &= \sqrt{100} \\
 &= 10 \\
 d(P_1, P_3) &= \sqrt{(4-7)^2 + (6-2)^2} \\
 &= \sqrt{(-3)^2 + 4^2} = \sqrt{9+16} \\
 &= \sqrt{25} \\
 &= 5
 \end{aligned}$$

Since  $[d(P_1, P_3)]^2 + [d(P_2, P_3)]^2 = [d(P_1, P_2)]^2$ , the triangle is a right triangle.

107. Let the coordinates of point  $B$  be  $(x, y)$ . Using the midpoint formula, we can write

$$(2, 3) = \left( \frac{-1+x}{2}, \frac{8+y}{2} \right).$$

This leads to two equations we can solve.

$$\begin{aligned}
 \frac{-1+x}{2} &= 2 & \frac{8+y}{2} &= 3 \\
 -1+x &= 4 & 8+y &= 6 \\
 x &= 5 & y &= -2
 \end{aligned}$$

Point  $B$  has coordinates  $(5, -2)$ .

108. Let the coordinates of point  $B$  be  $(x, y)$ . Using the midpoint formula, we can write

$$(5, -4) = \left( \frac{7+x}{2}, \frac{-2+y}{2} \right).$$

This leads to two equations we can solve.

$$\begin{aligned}
 \frac{7+x}{2} &= 5 & \frac{-2+y}{2} &= -4 \\
 7+x &= 10 & -2+y &= -8 \\
 x &= 3 & y &= -6
 \end{aligned}$$

Point  $B$  has coordinates  $(5, -2)$ .

109. Using the Pythagorean Theorem:

$$\begin{aligned}
 90^2 + 90^2 &= d^2 \\
 8100 + 8100 &= d^2 \\
 16200 &= d^2 \\
 d &= \sqrt{16200} = 90\sqrt{2} \approx 127.28 \text{ feet}
 \end{aligned}$$

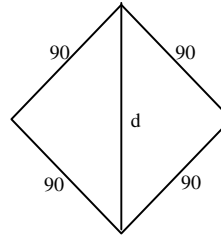

110. Using the Pythagorean Theorem:

$$\begin{aligned}
 60^2 + 60^2 &= d^2 \\
 3600 + 3600 &= d^2 \rightarrow 7200 = d^2 \\
 d &= \sqrt{7200} = 60\sqrt{2} \approx 84.85 \text{ feet}
 \end{aligned}$$

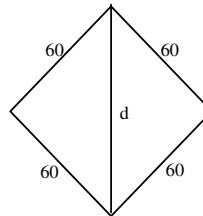

111. a. First:  $(90, 0)$ , Second:  $(90, 90)$   
Third:  $(0, 90)$

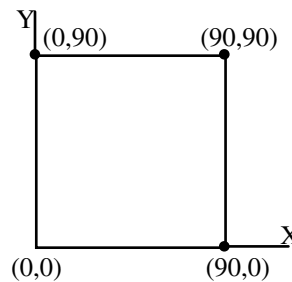

b. Using the distance formula:

$$\begin{aligned}
 d &= \sqrt{(310-90)^2 + (15-90)^2} \\
 &= \sqrt{220^2 + (-75)^2} = \sqrt{54025} \\
 &= 5\sqrt{2161} \approx 232.43 \text{ feet}
 \end{aligned}$$

**Section 1.1: The Distance and Midpoint Formulas; Graphing Utilities; Introduction to Graphing Equations**

c. Using the distance formula:

$$\begin{aligned} d &= \sqrt{(300-0)^2 + (300-90)^2} \\ &= \sqrt{300^2 + 210^2} = \sqrt{134100} \\ &= 30\sqrt{149} \approx 366.20 \text{ feet} \end{aligned}$$

112. a. First: (60, 0), Second: (60, 60)  
Third: (0, 60)

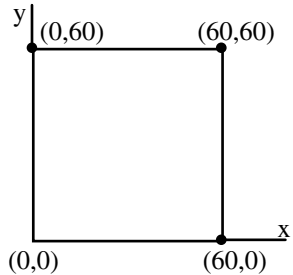

b. Using the distance formula:

$$\begin{aligned} d &= \sqrt{(180-60)^2 + (20-60)^2} \\ &= \sqrt{120^2 + (-40)^2} = \sqrt{16000} \\ &= 40\sqrt{10} \approx 126.49 \text{ feet} \end{aligned}$$

c. Using the distance formula:

$$\begin{aligned} d &= \sqrt{(220-0)^2 + (220-60)^2} \\ &= \sqrt{220^2 + 160^2} = \sqrt{74000} \\ &= 20\sqrt{185} \approx 272.03 \text{ feet} \end{aligned}$$

113. The car heading east moves a distance  $30t$  after  $t$  hours. The truck heading south moves a distance  $40t$  after  $t$  hours. Their distance apart after  $t$  hours is:

$$\begin{aligned} d &= \sqrt{(30t)^2 + (40t)^2} \\ &= \sqrt{900t^2 + 1600t^2} \\ &= \sqrt{2500t^2} \\ &= 50t \end{aligned}$$

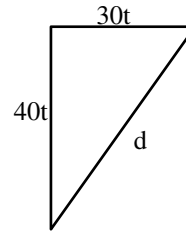

114.  $\frac{15 \text{ miles}}{1 \text{ hr}} \cdot \frac{5280 \text{ ft}}{1 \text{ mile}} \cdot \frac{1 \text{ hr}}{3600 \text{ sec}} = 22 \text{ ft/sec}$

$$\begin{aligned} d &= \sqrt{100^2 + (22t)^2} \\ &= \sqrt{10000 + 484t^2} \end{aligned}$$

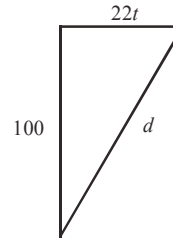

115. a. The shortest side is between  $P_1 = (2.6, 1.5)$  and  $P_2 = (2.7, 1.7)$ . The estimate for the desired intersection point is:

$$\begin{aligned} \left( \frac{x_1 + x_2}{2}, \frac{y_1 + y_2}{2} \right) &= \left( \frac{2.6 + 2.7}{2}, \frac{1.5 + 1.7}{2} \right) \\ &= \left( \frac{5.3}{2}, \frac{3.2}{2} \right) \\ &= (2.65, 1.6) \end{aligned}$$

b. Using the distance formula:

$$\begin{aligned} d &= \sqrt{(2.65-1.4)^2 + (1.6-1.3)^2} \\ &= \sqrt{(1.25)^2 + (0.3)^2} \\ &= \sqrt{1.5625 + 0.09} \\ &= \sqrt{1.6525} \\ &\approx 1.285 \text{ units} \end{aligned}$$

**Chapter 1: Graphs**

- 116.** Let  $P_1 = (2010, 405)$  and  $P_2 = (2014, 476)$ .

The midpoint is:

$$\begin{aligned} (x, y) &= \left( \frac{x_1 + x_2}{2}, \frac{y_1 + y_2}{2} \right) \\ &= \left( \frac{2010 + 2014}{2}, \frac{405 + 476}{2} \right) \\ &= \left( \frac{4024}{2}, \frac{881}{2} \right) \\ &= (2012, 440.5) \end{aligned}$$

The estimate is that net sales of Wal-Mart Stores, Inc. in 2012 was \$440.5 billion which is \$6.5 billion off from the reported value.

- 117.** For 2004 we have the ordered pair  $(2005, 19350)$  and for 2015 we have the ordered pair  $(2015, 24250)$ . The midpoint is

$$\begin{aligned} (\text{year}, \$) &= \left( \frac{2005 + 2015}{2}, \frac{19350 + 24250}{2} \right) \\ &= \left( \frac{4020}{2}, \frac{43600}{2} \right) \\ &= (2010, 21800) \end{aligned}$$

Using the midpoint, we estimate the poverty level in 2010 to be \$21,800.00. This is slightly lower than the actual value.

- 118. a.**

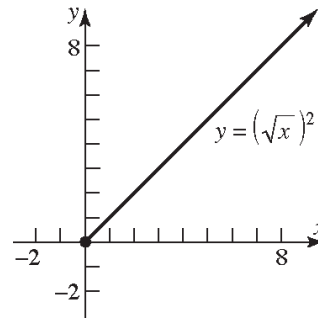
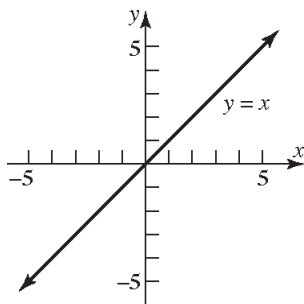
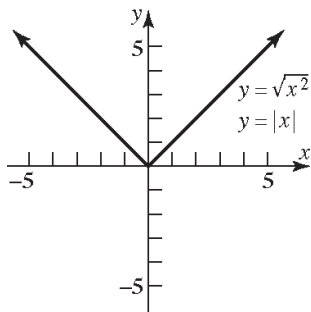

- b.** Since  $\sqrt{x^2} = |x|$  for all  $x$ , the graphs of  $y = \sqrt{x^2}$  and  $y = |x|$  are the same.
- c.** For  $y = (\sqrt{x})^2$ , the domain of the variable  $x$  is  $x \geq 0$ ; for  $y = x$ , the domain of the variable  $x$  is all real numbers. Thus,  $(\sqrt{x})^2 = x$  only for  $x \geq 0$ .
- d.** For  $y = \sqrt{x^2}$ , the range of the variable  $y$  is  $y \geq 0$ ; for  $y = x$ , the range of the variable  $y$  is all real numbers. Also,  $\sqrt{x^2} = x$  only if  $x \geq 0$ .

**119.** Answers will vary

**120.** Answers will vary

**121.** Answers will vary. A complete graph presents enough of the graph to the viewer so they can “see” the rest of the graph as an obvious continuation of what is shown.

**122.** Answers will vary.



Section 1.2

1.  $2(x+3)-1 = -7$

$2x+6-1 = -7$

$2x+5 = -7$

$2x = -12$

$x = -6$

The solution set is  $\{-6\}$

2.  $x^2 - 4x - 12 = 0$

$(x-6)(x+2) = 0$

$x-6 = 0$  or  $x+2 = 0$

$x = 6$                        $x = -2$

The solution set is  $\{-2, 6\}$ .

3. intercepts

4. y-axis

5. 4

6.  $(-3, 4)$

7. True

8. False; a graph can be symmetric with respect to both coordinate axes (in such cases it will also be symmetric with respect to the origin).

For example:  $x^2 + y^2 = 1$

9. a

10. c

11.  $y = x + 2$

x-intercept:                      y-intercept:

$0 = x + 2$

$y = 0 + 2$

$-2 = x$

$y = 2$

The intercepts are  $(-2, 0)$  and  $(0, 2)$ .

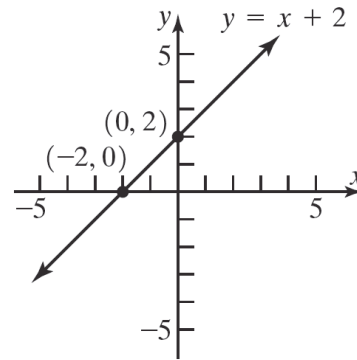

12.  $y = x - 6$

x-intercept:

$0 = x - 6$

$6 = x$

y-intercept:

$y = 0 - 6$

$y = -6$

The intercepts are  $(6, 0)$  and  $(0, -6)$ .

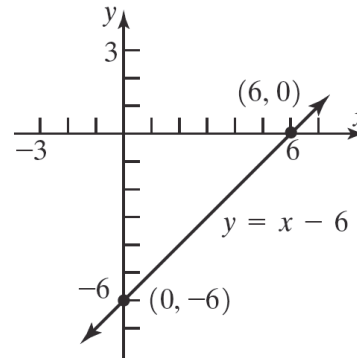

13.  $y = 2x + 8$

x-intercept:

$0 = 2x + 8$

$2x = -8$

$x = -4$

y-intercept:

$y = 2(0) + 8$

$y = 8$

The intercepts are  $(-4, 0)$  and  $(0, 8)$ .

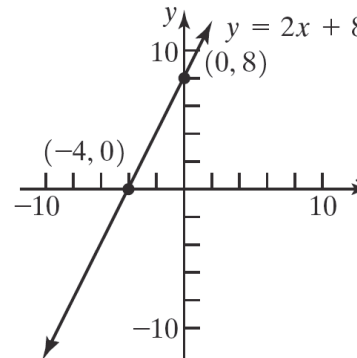

**Chapter 1: Graphs**

14.  $y = 3x - 9$

$x$ -intercept:	$y$ -intercept:
$0 = 3x - 9$	$y = 3(0) - 9$
$3x = 9$	$y = -9$
$x = 3$	

The intercepts are  $(3, 0)$  and  $(0, -9)$ .

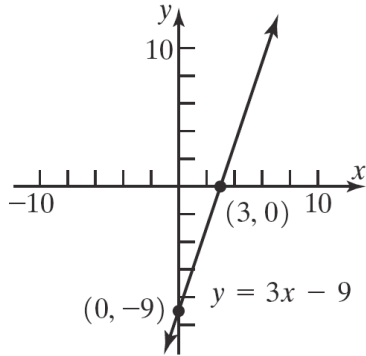

15.  $y = x^2 - 1$

$x$ -intercepts:	$y$ -intercept:
$0 = x^2 - 1$	$y = 0^2 - 1$
$x^2 = 1$	$y = -1$
$x = \pm 1$	

The intercepts are  $(-1, 0)$ ,  $(1, 0)$ , and  $(0, -1)$ .

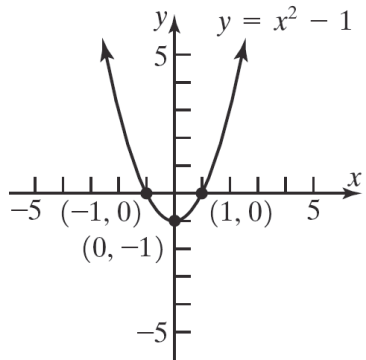

16.  $y = x^2 - 9$

$x$ -intercepts:	$y$ -intercept:
$0 = x^2 - 9$	$y = 0^2 - 9$
$x^2 = 9$	$y = -9$
$x = \pm 3$	

The intercepts are  $(-3, 0)$ ,  $(3, 0)$ , and  $(0, -9)$ .

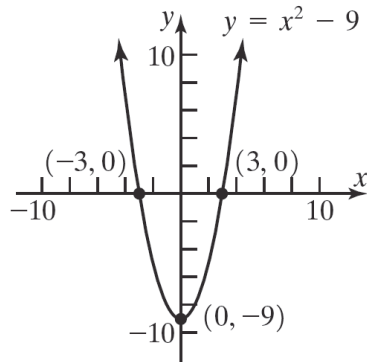

17.  $y = -x^2 + 4$

$x$ -intercepts:	$y$ -intercept:
$0 = -x^2 + 4$	$y = -(0)^2 + 4$
$x^2 = 4$	$y = 4$
$x = \pm 2$	

The intercepts are  $(-2, 0)$ ,  $(2, 0)$ , and  $(0, 4)$ .

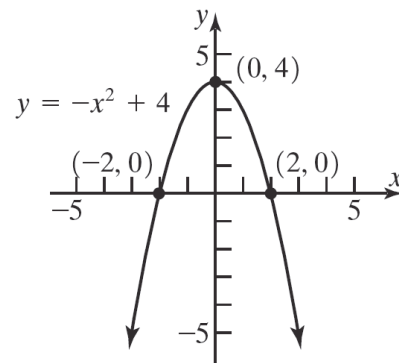

18.  $y = -x^2 + 1$

$x$ -intercepts:	$y$ -intercept:
$0 = -x^2 + 1$	$y = -(0)^2 + 1$
$x^2 = 1$	$y = 1$
$x = \pm 1$	

The intercepts are  $(-1, 0)$ ,  $(1, 0)$ , and  $(0, 1)$ .

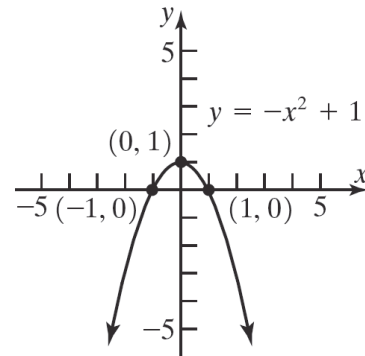

Section 1.2: Intercepts; Symmetry; Graphing Key Equations

19.  $2x + 3y = 6$

x-intercepts:	y-intercept:
$2x + 3(0) = 6$	$2(0) + 3y = 6$
$2x = 6$	$3y = 6$
$x = 3$	$y = 2$

The intercepts are  $(3, 0)$  and  $(0, 2)$ .

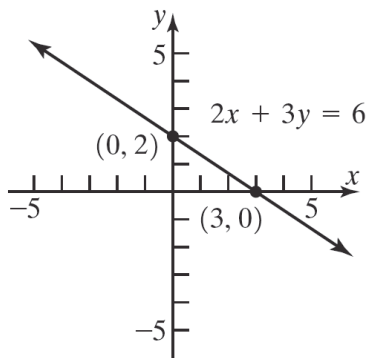

20.  $5x + 2y = 10$

x-intercepts:	y-intercept:
$5x + 2(0) = 10$	$5(0) + 2y = 10$
$5x = 10$	$2y = 10$
$x = 2$	$y = 5$

The intercepts are  $(2, 0)$  and  $(0, 5)$ .

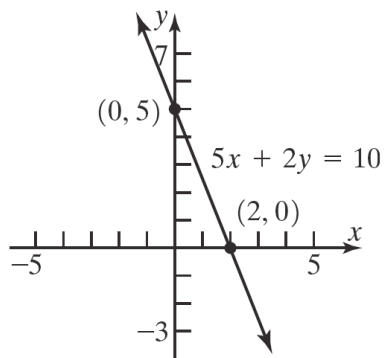

21.  $9x^2 + 4y = 36$

x-intercepts:	y-intercept:
$9x^2 + 4(0) = 36$	$9(0)^2 + 4y = 36$
$9x^2 = 36$	$4y = 36$
$x^2 = 4$	$y = 9$
$x = \pm 2$	

The intercepts are  $(-2, 0)$ ,  $(2, 0)$ , and  $(0, 9)$ .

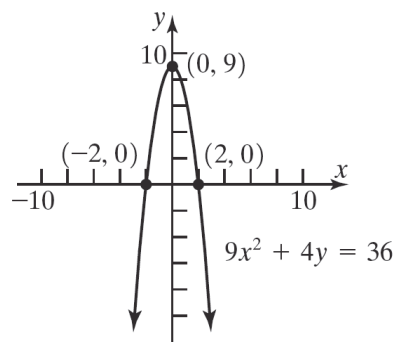

22.  $4x^2 + y = 4$

x-intercepts:	y-intercept:
$4x^2 + 0 = 4$	$4(0)^2 + y = 4$
$4x^2 = 4$	$y = 4$
$x^2 = 1$	
$x = \pm 1$	

The intercepts are  $(-1, 0)$ ,  $(1, 0)$ , and  $(0, 4)$ .

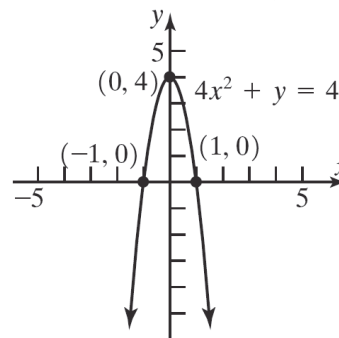

23.

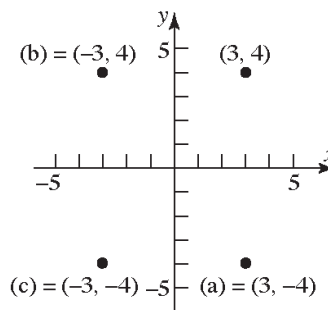

24.

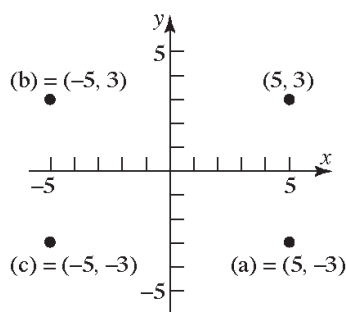

Chapter 1: Graphs

25.

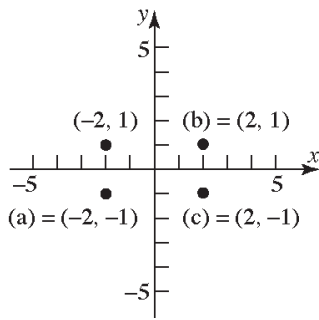

30.

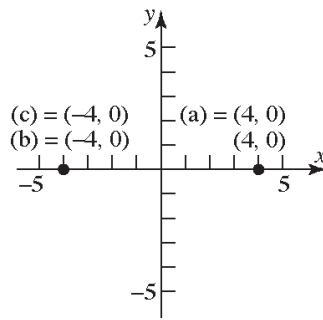

26.

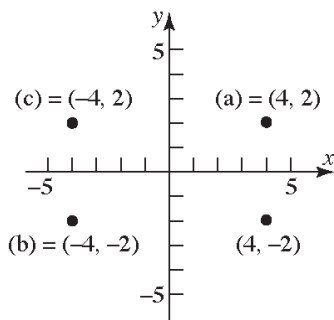

31.

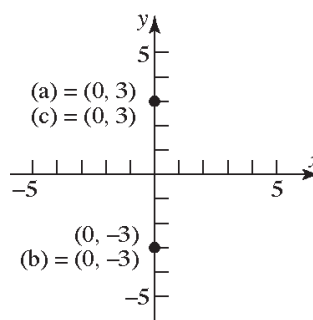

27.

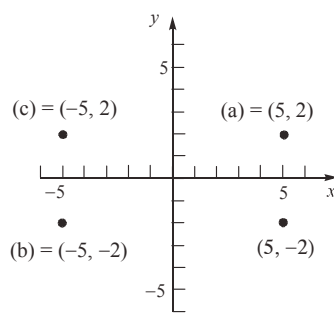

32.

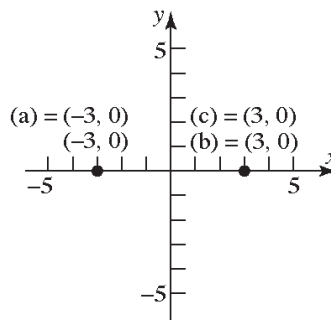

28.

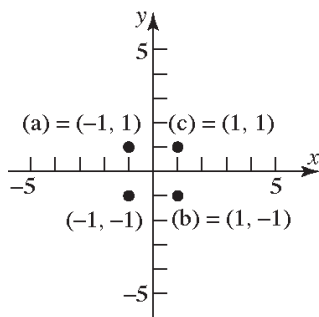

33. a. Intercepts:  $(-1, 0)$  and  $(1, 0)$

b. Symmetric with respect to the  $x$ -axis,  $y$ -axis, and the origin.

34. a. Intercepts:  $(0, 1)$

b. Not symmetric to the  $x$ -axis, the  $y$ -axis, nor the origin

29.

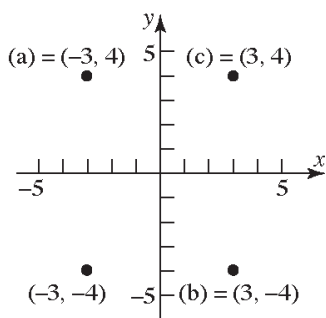

35. a. Intercepts:  $(-\frac{\pi}{2}, 0)$ ,  $(0, 1)$ , and  $(\frac{\pi}{2}, 0)$

b. Symmetric with respect to the  $y$ -axis.

36. a. Intercepts:  $(-2, 0)$ ,  $(0, -3)$ , and  $(2, 0)$

b. Symmetric with respect to the  $y$ -axis.

37. a. Intercepts:  $(0, 0)$

b. Symmetric with respect to the  $x$ -axis.

Section 1.2: Intercepts; Symmetry; Graphing Key Equations

38. a. Intercepts:  $(-2, 0)$ ,  $(0, 2)$ ,  $(0, -2)$ , and  $(2, 0)$   
 b. Symmetric with respect to the  $x$ -axis,  $y$ -axis, and the origin.
39. a. Intercepts:  $(-2, 0)$ ,  $(0, 0)$ , and  $(2, 0)$   
 b. Symmetric with respect to the origin.
40. a. Intercepts:  $(-4, 0)$ ,  $(0, 0)$ , and  $(4, 0)$   
 b. Symmetric with respect to the origin.
41. a.  $x$ -intercept:  $[-2, 1]$ ,  $y$ -intercept 0  
 b. Not symmetric to  $x$ -axis,  $y$ -axis, or origin.
42. a.  $x$ -intercept:  $[-1, 2]$ ,  $y$ -intercept 0  
 b. Not symmetric to  $x$ -axis,  $y$ -axis, or origin.
43. a. Intercepts: none  
 b. Symmetric with respect to the origin.
44. a. Intercepts: none  
 b. Symmetric with respect to the  $x$ -axis.

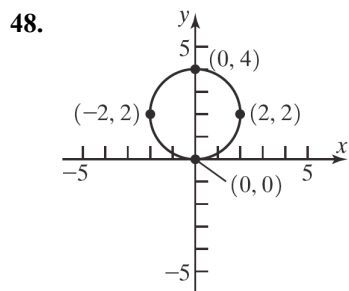
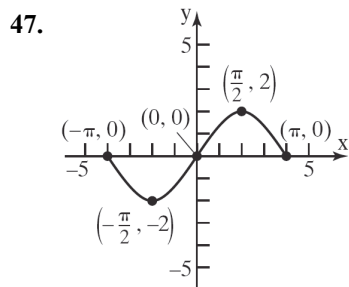
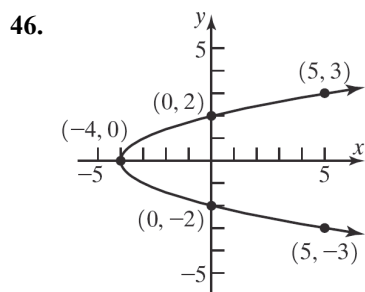
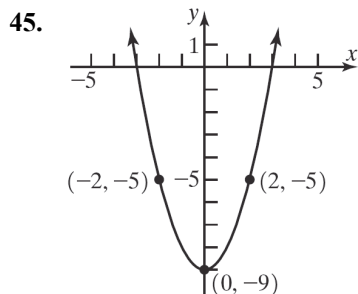

49.  $y^2 = x + 4$   
 $x$ -intercepts:  $0^2 = x + 4$   
 $-4 = x$   
 $y$ -intercepts:  $y^2 = 0 + 4$   
 $y^2 = 4$   
 $y = \pm 2$

The intercepts are  $(-4, 0)$ ,  $(0, -2)$  and  $(0, 2)$ .

Test  $x$ -axis symmetry: Let  $y = -y$

$$(-y)^2 = x + 4$$

$$y^2 = x + 4 \text{ same}$$

Test  $y$ -axis symmetry: Let  $x = -x$

$$y^2 = -x + 4 \text{ different}$$

Test origin symmetry: Let  $x = -x$  and  $y = -y$ .

$$(-y)^2 = -x + 4$$

$$y^2 = -x + 4 \text{ different}$$

Therefore, the graph will have  $x$ -axis symmetry.

50.  $y^2 = x + 9$   
 $x$ -intercepts:  $(0)^2 = -x + 9$   
 $0 = -x + 9$   
 $x = 9$   
 $y$ -intercepts:  $y^2 = 0 + 9$   
 $y^2 = 9$   
 $y = \pm 3$

The intercepts are  $(-9, 0)$ ,  $(0, -3)$  and  $(0, 3)$ .

Test  $x$ -axis symmetry: Let  $y = -y$

$$(-y)^2 = x + 9$$

$$y^2 = x + 9 \text{ same}$$

**Chapter 1: Graphs**

Test y-axis symmetry: Let  $x = -x$

$$y^2 = -x + 9 \text{ different}$$

Test origin symmetry: Let  $x = -x$  and  $y = -y$ .

$$(-y)^2 = -x + 9$$

$$y^2 = -x + 9 \text{ different}$$

Therefore, the graph will have  $x$ -axis symmetry.

51.  $y = \sqrt[3]{x}$

$x$ -intercepts:  $y$ -intercepts:

$$0 = \sqrt[3]{x} \quad y = \sqrt[3]{0} = 0$$

$$0 = x$$

The only intercept is  $(0, 0)$ .

Test x-axis symmetry: Let  $y = -y$

$$-y = \sqrt[3]{x} \text{ different}$$

Test y-axis symmetry: Let  $x = -x$

$$y = \sqrt[3]{-x} = -\sqrt[3]{x} \text{ different}$$

Test origin symmetry: Let  $x = -x$  and  $y = -y$

$$-y = \sqrt[3]{-x} = -\sqrt[3]{x}$$

$$y = \sqrt[3]{x} \text{ same}$$

Therefore, the graph will have origin symmetry.

52.  $y = \sqrt[5]{x}$

$x$ -intercepts:  $y$ -intercepts:

$$0 = \sqrt[5]{x} \quad y = \sqrt[5]{0} = 0$$

$$0 = x$$

The only intercept is  $(0, 0)$ .

Test x-axis symmetry: Let  $y = -y$

$$-y = \sqrt[5]{x} \text{ different}$$

Test y-axis symmetry: Let  $x = -x$

$$y = \sqrt[5]{-x} = -\sqrt[5]{x} \text{ different}$$

Test origin symmetry: Let  $x = -x$  and  $y = -y$

$$-y = \sqrt[5]{-x} = -\sqrt[5]{x}$$

$$y = \sqrt[5]{x} \text{ same}$$

Therefore, the graph will have origin symmetry.

53.  $x^2 + y - 9 = 0$

$x$ -intercepts:  $y$ -intercepts:

$$x^2 - 9 = 0 \quad 0^2 + y - 9 = 0$$

$$x^2 = 9 \quad y = 9$$

$$x = \pm 3$$

The intercepts are  $(-3, 0)$ ,  $(3, 0)$ , and  $(0, 9)$ .

Test x-axis symmetry: Let  $y = -y$

$$x^2 - y - 9 = 0 \text{ different}$$

Test y-axis symmetry: Let  $x = -x$

$$(-x)^2 + y - 9 = 0$$

$$x^2 + y - 9 = 0 \text{ same}$$

Test origin symmetry: Let  $x = -x$  and  $y = -y$

$$(-x)^2 - y - 9 = 0$$

$$x^2 - y - 9 = 0 \text{ different}$$

Therefore, the graph will have  $y$ -axis symmetry.

54.  $x^2 - y - 4 = 0$

$x$ -intercepts:  $y$ -intercept:

$$x^2 - 0 - 4 = 0 \quad 0^2 - y - 4 = 0$$

$$x^2 = 4 \quad -y = 4$$

$$x = \pm 2 \quad y = -4$$

The intercepts are  $(-2, 0)$ ,  $(2, 0)$ , and  $(0, -4)$ .

Test x-axis symmetry: Let  $y = -y$

$$x^2 - (-y) - 4 = 0$$

$$x^2 + y - 4 = 0 \text{ different}$$

Test y-axis symmetry: Let  $x = -x$

$$(-x)^2 - y - 4 = 0$$

$$x^2 - y - 4 = 0 \text{ same}$$

Test origin symmetry: Let  $x = -x$  and  $y = -y$

$$(-x)^2 - (-y) - 4 = 0$$

$$x^2 + y - 4 = 0 \text{ different}$$

Therefore, the graph will have  $y$ -axis symmetry.

**Section 1.2: Intercepts; Symmetry; Graphing Key Equations**

55.  $9x^2 + 4y^2 = 36$

x-intercepts:	y-intercepts:
$9x^2 + 4(0)^2 = 36$	$9(0)^2 + 4y^2 = 36$
$9x^2 = 36$	$4y^2 = 36$
$x^2 = 4$	$y^2 = 9$
$x = \pm 2$	$y = \pm 3$

The intercepts are  $(-2, 0)$ ,  $(2, 0)$ ,  $(0, -3)$ , and  $(0, 3)$ .

Test x-axis symmetry: Let  $y = -y$

$$9x^2 + 4(-y)^2 = 36$$

$$9x^2 + 4y^2 = 36 \text{ same}$$

Test y-axis symmetry: Let  $x = -x$

$$9(-x)^2 + 4y^2 = 36$$

$$9x^2 + 4y^2 = 36 \text{ same}$$

Test origin symmetry: Let  $x = -x$  and  $y = -y$

$$9(-x)^2 + 4(-y)^2 = 36$$

$$9x^2 + 4y^2 = 36 \text{ same}$$

Therefore, the graph will have x-axis, y-axis, and origin symmetry.

56.  $4x^2 + y^2 = 4$

x-intercepts:	y-intercepts:
$4x^2 + 0^2 = 4$	$4(0)^2 + y^2 = 4$
$4x^2 = 4$	$y^2 = 4$
$x^2 = 1$	$y = \pm 2$
$x = \pm 1$	

The intercepts are  $(-1, 0)$ ,  $(1, 0)$ ,  $(0, -2)$ , and  $(0, 2)$ .

Test x-axis symmetry: Let  $y = -y$

$$4x^2 + (-y)^2 = 4$$

$$4x^2 + y^2 = 4 \text{ same}$$

Test y-axis symmetry: Let  $x = -x$

$$4(-x)^2 + y^2 = 4$$

$$4x^2 + y^2 = 4 \text{ same}$$

Test origin symmetry: Let  $x = -x$  and  $y = -y$

$$4(-x)^2 + (-y)^2 = 4$$

$$4x^2 + y^2 = 4 \text{ same}$$

Therefore, the graph will have x-axis, y-axis, and origin symmetry.

57.  $y = x^3 - 27$

x-intercepts:	y-intercepts:
$0 = x^3 - 27$	$y = 0^3 - 27$
$x^3 = 27$	$y = -27$
$x = 3$	

The intercepts are  $(3, 0)$  and  $(0, -27)$ .

Test x-axis symmetry: Let  $y = -y$

$$-y = x^3 - 27 \text{ different}$$

Test y-axis symmetry: Let  $x = -x$

$$y = (-x)^3 - 27$$

$$y = -x^3 - 27 \text{ different}$$

Test origin symmetry: Let  $x = -x$  and  $y = -y$

$$-y = (-x)^3 - 27$$

$$y = x^3 + 27 \text{ different}$$

Therefore, the graph has none of the indicated symmetries.

58.  $y = x^4 - 1$

x-intercepts:	y-intercepts:
$0 = x^4 - 1$	$y = 0^4 - 1$
$x^4 = 1$	$y = -1$
$x = \pm 1$	

The intercepts are  $(-1, 0)$ ,  $(1, 0)$ , and  $(0, -1)$ .

Test x-axis symmetry: Let  $y = -y$

$$-y = x^4 - 1 \text{ different}$$

Test y-axis symmetry: Let  $x = -x$

$$y = (-x)^4 - 1$$

$$y = x^4 - 1 \text{ same}$$

Test origin symmetry: Let  $x = -x$  and  $y = -y$

$$-y = (-x)^4 - 1$$

$$-y = x^4 - 1 \text{ different}$$

Therefore, the graph will have y-axis symmetry.

**Chapter 1: Graphs**

59.  $y = x^2 - 3x - 4$

x-intercepts:  $0 = x^2 - 3x - 4$   
 y-intercepts:  $y = 0^2 - 3(0) - 4$

$0 = (x-4)(x+1)$   $y = -4$

$x = 4$  or  $x = -1$

The intercepts are  $(4, 0)$ ,  $(-1, 0)$ , and  $(0, -4)$ .

Test x-axis symmetry: Let  $y = -y$

$-y = x^2 - 3x - 4$  different

Test y-axis symmetry: Let  $x = -x$

$y = (-x)^2 - 3(-x) - 4$

$y = x^2 + 3x - 4$  different

Test origin symmetry: Let  $x = -x$  and  $y = -y$

$-y = (-x)^2 - 3(-x) - 4$

$-y = x^2 + 3x - 4$  different

Therefore, the graph has none of the indicated symmetries.

60.  $y = x^2 + 4$

x-intercepts:  $0 = x^2 + 4$   
 y-intercepts:  $y = 0^2 + 4$

$x^2 = -4$   $y = 4$

no real solution

The only intercept is  $(0, 4)$ .

Test x-axis symmetry: Let  $y = -y$

$-y = x^2 + 4$  different

Test y-axis symmetry: Let  $x = -x$

$y = (-x)^2 + 4$

$y = x^2 + 4$  same

Test origin symmetry: Let  $x = -x$  and  $y = -y$

$-y = (-x)^2 + 4$

$-y = x^2 + 4$  different

Therefore, the graph will have y-axis symmetry.

61.  $y = \frac{3x}{x^2 + 9}$

x-intercepts:  $0 = \frac{3x}{x^2 + 9}$   
 y-intercepts:  $y = \frac{3(0)}{0^2 + 9} = \frac{0}{9} = 0$

$0 = \frac{3x}{x^2 + 9}$   $y = \frac{3(0)}{0^2 + 9} = \frac{0}{9} = 0$

$3x = 0$

$x = 0$

The only intercept is  $(0, 0)$ .

Test x-axis symmetry: Let  $y = -y$

$-y = \frac{3x}{x^2 + 9}$  different

Test y-axis symmetry: Let  $x = -x$

$y = \frac{3(-x)}{(-x)^2 + 9}$

$y = -\frac{3x}{x^2 + 9}$  different

Test origin symmetry: Let  $x = -x$  and  $y = -y$

$-y = \frac{3(-x)}{(-x)^2 + 9}$

$-y = -\frac{3x}{x^2 + 9}$

$y = \frac{3x}{x^2 + 9}$  same

Therefore, the graph has origin symmetry.

62.  $y = \frac{x^2 - 4}{2x}$

x-intercepts:  $0 = \frac{x^2 - 4}{2x}$   
 y-intercepts:  $y = \frac{0^2 - 4}{2(0)} = \frac{-4}{0}$

$x^2 - 4 = 0$

$x^2 = 4$

$x = \pm 2$

undefined

The intercepts are  $(-2, 0)$  and  $(2, 0)$ .

Test x-axis symmetry: Let  $y = -y$

$-y = \frac{x^2 - 4}{2x}$  different

Test y-axis symmetry: Let  $x = -x$

$y = \frac{(-x)^2 - 4}{2(-x)}$

$y = -\frac{x^2 - 4}{2x}$  different



**Section 1.2: Intercepts; Symmetry; Graphing Key Equations**

Test origin symmetry: Let  $x = -x$  and  $y = -y$

$$-y = \frac{(-x)^2 - 4}{2(-x)}$$

$$-y = \frac{x^2 - 4}{-2x}$$

$$y = \frac{x^2 - 4}{2x} \text{ same}$$

Therefore, the graph has origin symmetry.

63.  $y = \frac{-x^3}{x^2 - 9}$

x-intercepts:

$$0 = \frac{-x^3}{x^2 - 9}$$

$$-x^3 = 0$$

$$x = 0$$

The only intercept is  $(0, 0)$ .

Test x-axis symmetry: Let  $y = -y$

$$-y = \frac{-x^3}{x^2 - 9}$$

$$y = \frac{x^3}{x^2 - 9} \text{ different}$$

Test y-axis symmetry: Let  $x = -x$

$$y = \frac{-(-x)^3}{(-x)^2 - 9}$$

$$y = \frac{x^3}{x^2 - 9} \text{ different}$$

Test origin symmetry: Let  $x = -x$  and  $y = -y$

$$-y = \frac{-(-x)^3}{(-x)^2 - 9}$$

$$-y = \frac{x^3}{x^2 - 9}$$

$$y = \frac{-x^3}{x^2 - 9} \text{ same}$$

Therefore, the graph has origin symmetry.

64.  $y = \frac{x^4 + 1}{2x^5}$

x-intercepts:

y-intercepts:

$$0 = \frac{x^4 + 1}{2x^5} \quad y = \frac{0^4 + 1}{2(0)^5} = \frac{1}{0}$$

$$x^4 = -1$$

no real solution

There are no intercepts for the graph of this equation.

Test x-axis symmetry: Let  $y = -y$

$$-y = \frac{x^4 + 1}{2x^5} \text{ different}$$

Test y-axis symmetry: Let  $x = -x$

$$y = \frac{(-x)^4 + 1}{2(-x)^5}$$

$$y = \frac{x^4 + 1}{-2x^5} \text{ different}$$

Test origin symmetry: Let  $x = -x$  and  $y = -y$

$$-y = \frac{(-x)^4 + 1}{2(-x)^5}$$

$$-y = \frac{x^4 + 1}{-2x^5}$$

$$y = \frac{x^4 + 1}{2x^5} \text{ same}$$

Therefore, the graph has origin symmetry.

65.  $y = x^3$

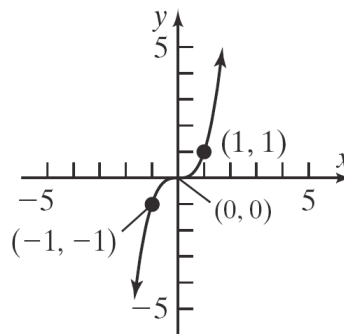

**Chapter 1: Graphs**

66.  $x = y^2$

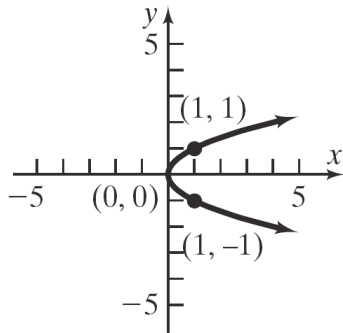

67.  $y = \sqrt{x}$

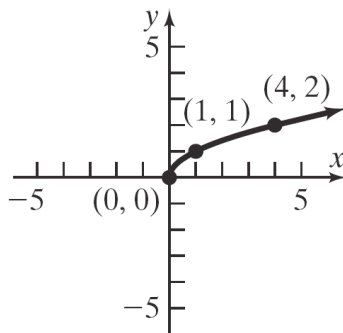

68.  $y = \frac{1}{x}$

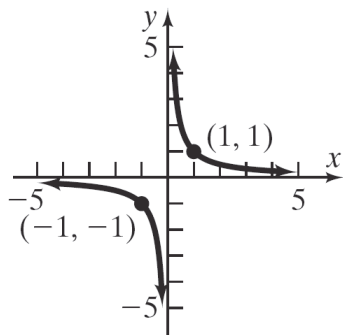

69. If the point  $(3, b)$  is on the graph of  $y = 4x + 1$ , then we have  $b = 4(3) + 1 = 12 + 1 = 13$ . Thus,  $b = 13$ .

70. If the point  $(-2, b)$  is on the graph of  $2x + 3y = 2$ , then we have  
 $2(-2) + 3(b) = 2$   
 $-4 + 3b = 2$   
 $3b = 6$   
 $b = 2$   
 Thus,  $b = 2$ .

71. If the point  $(a, 4)$  is on the graph of  $y = x^2 + 3x$ , then we have  
 $4 = a^2 + 3a$   
 $0 = a^2 + 3a - 4$   
 $0 = (a + 4)(a - 1)$   
 $a + 4 = 0$  or  $a - 1 = 0$   
 $a = -4$  or  $a = 1$   
 Thus,  $a = -4$  or  $a = 1$ .

72. If the point  $(a, -5)$  is on the graph of  $y = x^2 + 6x$ , then we have  
 $-5 = a^2 + 6a$   
 $0 = a^2 + 6a + 5$   
 $0 = (a + 5)(a + 1)$   
 $a + 5 = 0$  or  $a + 1 = 0$   
 $a = -5$  or  $a = -1$   
 Thus,  $a = -5$  or  $a = -1$ .

73. a.  $0 = x^2 - 5$   
 $x^2 = 5$   
 $x = \pm\sqrt{5}$   
 The x-intercepts are  $x = -\sqrt{5}$  and  $x = \sqrt{5}$ .  
 $y = (0)^2 - 5 = -5$   
 The y-intercept is  $y = -5$ .  
 The intercepts are  $(-\sqrt{5}, 0)$ ,  $(\sqrt{5}, 0)$ , and  $(0, -5)$ .

b. x-axis (replace  $y$  by  $-y$ ):  
 $-y = x^2 - 5$   
 $y = 5 - x^2$  different  
 y-axis (replace  $x$  by  $-x$ ):  
 $y = (-x)^2 - 5 = x^2 - 5$  same  
 origin (replace  $x$  by  $-x$  and  $y$  by  $-y$ ):  
 $-y = (-x)^2 - 5$   
 $y = 5 - x^2$  different  
 The equation has y-axis symmetry.

Section 1.2: Intercepts; Symmetry; Graphing Key Equations

c.  $y = x^2 - 5$

Additional points:

$x$	$y = x^2 - 5$	$(x, y)$
1	$y = 1^2 - 5 = -4$	$(1, -4)$
-1	from symmetry	$(-1, -4)$
2	$y = 2^2 - 5 = -1$	$(2, -1)$
-2	from symmetry	$(-2, -1)$

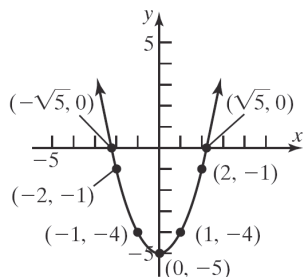

c.  $y = x^2 - 8$

Additional points:

$x$	$y = x^2 - 8$	$(x, y)$
1	$y = 1^2 - 8 = -7$	$(1, -7)$
-1	from symmetry	$(-1, -7)$
2	$y = 2^2 - 8 = -4$	$(2, -4)$
-2	from symmetry	$(-2, -4)$

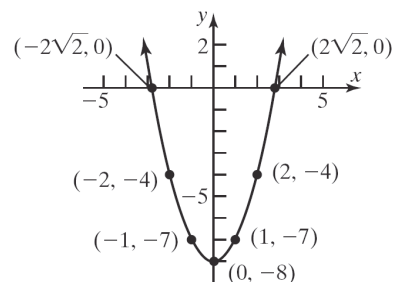

74. a.  $0 = x^2 - 8$

$$x^2 = 8$$

$$x = \pm 2\sqrt{2}$$

The x-intercepts are  $x = -2\sqrt{2}$  and

$$x = 2\sqrt{2}.$$

$$y = (0)^2 - 8 = -8$$

The y-intercept is  $y = -8$ .

The intercepts are  $(-2\sqrt{2}, 0)$ ,  $(2\sqrt{2}, 0)$ , and  $(0, -8)$ .

b. x-axis (replace  $y$  by  $-y$ ):

$$-y = x^2 - 8$$

$$y = 8 - x^2 \text{ different}$$

y-axis (replace  $x$  by  $-x$ ):

$$y = (-x)^2 - 8 = x^2 - 8 \text{ same}$$

origin (replace  $x$  by  $-x$  and  $y$  by  $-y$ ):

$$-y = (-x)^2 - 8$$

$$y = 8 - x^2 \text{ different}$$

The equation has y-axis symmetry.

75. a.  $x - (0)^2 = -9$

$$x = -9$$

The x-intercept is  $x = -9$ .

$$(0) - y^2 = -9$$

$$-y^2 = -9$$

$$y^2 = 9 \rightarrow y = \pm 3$$

The y-intercepts are  $y = -3$  and  $y = 3$ .

The intercepts are  $(-9, 0)$ ,  $(0, -3)$ , and  $(0, 3)$ .

b. x-axis (replace  $y$  by  $-y$ ):

$$x - (-y)^2 = -9$$

$$x - y^2 = -9 \text{ same}$$

y-axis (replace  $x$  by  $-x$ ):

$$-x - y^2 = -9$$

$$x + y^2 = 9 \text{ different}$$

origin (replace  $x$  by  $-x$  and  $y$  by  $-y$ ):

$$-x - (-y)^2 = -9$$

$$-x - y^2 = -9$$

$$x + y^2 = 9 \text{ different}$$

The equation has x-axis symmetry.

**Chapter 1: Graphs**

c.  $x - y^2 = -9$  or  $x = y^2 - 9$

Additional points:

$y$	$x = y^2 - 9$	$(x, y)$
2	$x = 2^2 - 9 = -5$	$(-5, 2)$
-2	from symmetry	$(-5, -2)$

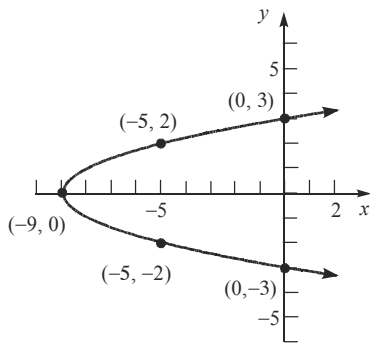

76. a.  $x + (0)^2 = 4$

$x = 4$

The x-intercept is  $x = 4$ .

$(0) + y^2 = 4$

$y^2 = 4 \rightarrow y = \pm 2$

The y-intercepts are  $y = -2$  and  $y = 2$ .

The intercepts are  $(4, 0)$ ,  $(0, -2)$ , and  $(0, 2)$ .

b. x-axis (replace  $y$  by  $-y$ ):

$x + (-y)^2 = 4$

$x + y^2 = 4$  same

y-axis (replace  $x$  by  $-x$ ):

$-x + y^2 = 4$

$x - y^2 = -4$  different

origin (replace  $x$  by  $-x$  and  $y$  by  $-y$ ):

$-x + (-y)^2 = 4$

$-x + y^2 = 4$

$x - y^2 = -4$  different

The equation has x-axis symmetry.

c.  $x + y^2 = 4$  or  $x = 4 - y^2$

Additional points:

$y$	$x = 4 - y^2$	$(x, y)$
1	$x = 4 - 1^2 = 3$	$(3, 1)$
-1	from symmetry	$(3, -1)$

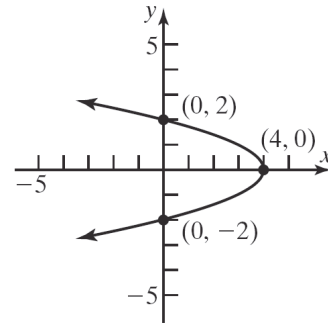

77. a.  $x^2 + (0)^2 = 9$

$x^2 = 9$

$x = \pm 3$

The x-intercepts are  $x = -3$  and  $x = 3$ .

$(0)^2 + y^2 = 9$

$y^2 = 9$

$y = \pm 3$

The y-intercepts are  $y = -3$  and  $y = 3$ .

The intercepts are  $(-3, 0)$ ,  $(3, 0)$ ,  $(0, -3)$ , and  $(0, 3)$ .

b. x-axis (replace  $y$  by  $-y$ ):

$x^2 + (-y)^2 = 9$

$x^2 + y^2 = 9$  same

y-axis (replace  $x$  by  $-x$ ):

$(-x)^2 + y^2 = 9$

$x^2 + y^2 = 9$  same

origin (replace  $x$  by  $-x$  and  $y$  by  $-y$ ):

$(-x)^2 + (-y)^2 = 9$

$x^2 + y^2 = 9$  same

The equation has x-axis symmetry, y-axis symmetry, and origin symmetry.

Section 1.2: Intercepts; Symmetry; Graphing Key Equations

c.  $x^2 + y^2 = 9$

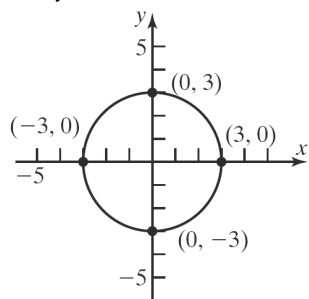

78. a.  $x^2 + (0)^2 = 16$

$$x^2 = 16$$

$$x = \pm 4$$

The x-intercepts are  $x = -4$  and  $x = 4$ .

$$(0)^2 + y^2 = 16$$

$$y^2 = 16$$

$$y = \pm 4$$

The y-intercepts are  $y = -4$  and  $y = 4$ .

The intercepts are  $(-4, 0)$ ,  $(4, 0)$ ,  $(0, -4)$ , and  $(0, 4)$ .

b. x-axis (replace  $y$  by  $-y$ ):

$$x^2 + (-y)^2 = 16$$

$$x^2 + y^2 = 16 \text{ same}$$

y-axis (replace  $x$  by  $-x$ ):

$$(-x)^2 + y^2 = 16$$

$$x^2 + y^2 = 16 \text{ same}$$

origin (replace  $x$  by  $-x$  and  $y$  by  $-y$ ):

$$(-x)^2 + (-y)^2 = 16$$

$$x^2 + y^2 = 16 \text{ same}$$

The equation has x-axis symmetry, y-axis symmetry, and origin symmetry.

c.  $x^2 + y^2 = 16$

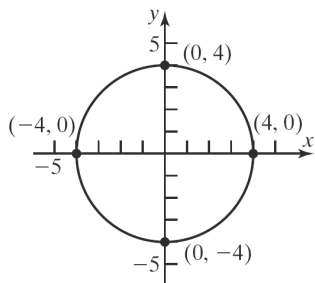

79. a.  $0 = x^3 - 4x$

$$0 = x(x^2 - 4)$$

$$x = 0 \text{ or } x^2 - 4 = 0$$

$$x^2 = 4$$

$$x = \pm 2$$

The x-intercepts are  $x = 0$ ,  $x = -2$ , and  $x = 2$ .

$$y = 0^3 - 4(0) = 0$$

The y-intercept is  $y = 0$ .

The intercepts are  $(0, 0)$ ,  $(-2, 0)$ , and  $(2, 0)$ .

b. x-axis (replace  $y$  by  $-y$ ):

$$-y = x^3 - 4x$$

$$y = 4x - x^3 \text{ different}$$

y-axis (replace  $x$  by  $-x$ ):

$$y = (-x)^3 - 4(-x)$$

$$y = -x^3 + 4x \text{ different}$$

origin (replace  $x$  by  $-x$  and  $y$  by  $-y$ ):

$$-y = (-x)^3 - 4(-x)$$

$$-y = -x^3 + 4x$$

$$y = x^3 - 4x \text{ same}$$

The equation has origin symmetry.

c.  $y = x^3 - 4x$

Additional points:

$x$	$y = x^3 - 4x$	$(x, y)$
1	$y = 1^3 - 4(1) = -3$	$(1, -3)$
-1	from symmetry	$(-1, 3)$

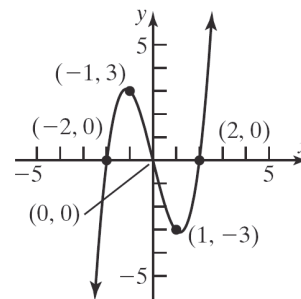

**Chapter 1: Graphs**

**80. a.**  $0 = x^3 - x$

$$0 = x(x^2 - 1)$$

$$x = 0 \text{ or } x^2 - 1 = 0$$

$$x^2 = 1$$

$$x = \pm 1$$

The x-intercepts are  $x = 0$ ,  $x = -1$ , and  $x = 1$ .

$$y = 0^3 - (0) = 0$$

The y-intercept is  $y = 0$ .

The intercepts are  $(0,0)$ ,  $(-1,0)$ , and  $(1,0)$ .

**b.** x-axis (replace  $y$  by  $-y$ ):

$$-y = x^3 - x$$

$$y = x - x^3 \text{ different}$$

y-axis (replace  $x$  by  $-x$ ):

$$y = (-x)^3 - (-x)$$

$$y = -x^3 + x \text{ different}$$

origin (replace  $x$  by  $-x$  and  $y$  by  $-y$ ):

$$-y = (-x)^3 - (-x)$$

$$-y = -x^3 + x$$

$$y = x^3 - x \text{ same}$$

The equation has origin symmetry.

**c.**  $y = x^3 - 4x$

Additional points:

$x$	$y = x^3 - 4x$	$(x, y)$
2	$y = 2^3 - (2) = 6$	$(2, 6)$
-2	from symmetry	$(-2, -6)$

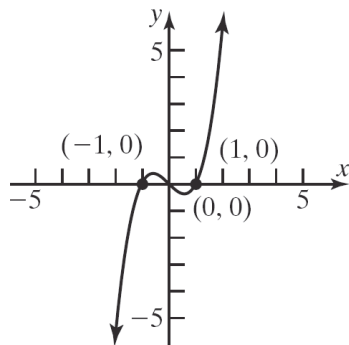

**81.** For a graph with origin symmetry, if the point  $(a,b)$  is on the graph, then so is the point  $(-a,-b)$ . Since the point  $(1,2)$  is on the graph of an equation with origin symmetry, the point  $(-1,-2)$  must also be on the graph.

**82.** For a graph with y-axis symmetry, if the point  $(a,b)$  is on the graph, then so is the point  $(-a,b)$ . Since 6 is an x-intercept in this case, the point  $(6,0)$  is on the graph of the equation. Due to the y-axis symmetry, the point  $(-6,0)$  must also be on the graph. Therefore,  $-6$  is another x-intercept.

**83.** For a graph with origin symmetry, if the point  $(a,b)$  is on the graph, then so is the point  $(-a,-b)$ . Since  $-4$  is an x-intercept in this case, the point  $(-4,0)$  is on the graph of the equation. Due to the origin symmetry, the point  $(4,0)$  must also be on the graph. Therefore,  $4$  is another x-intercept.

**84.** For a graph with x-axis symmetry, if the point  $(a,b)$  is on the graph, then so is the point  $(a,-b)$ . Since 2 is a y-intercept in this case, the point  $(0,2)$  is on the graph of the equation. Due to the x-axis symmetry, the point  $(0,-2)$  must also be on the graph. Therefore,  $-2$  is another y-intercept.

**85. a.**  $(x^2 + y^2 - x)^2 = x^2 + y^2$

x-intercepts:

$$(x^2 + (0)^2 - x)^2 = x^2 + (0)^2$$

$$(x^2 - x)^2 = x^2$$

$$x^4 - 2x^3 + x^2 = x^2$$

$$x^4 - 2x^3 = 0$$

$$x^3(x-2) = 0$$

$$x^3 = 0 \text{ or } x-2 = 0$$

$$x = 0 \qquad x = 2$$

**Section 1.2: Intercepts; Symmetry; Graphing Key Equations**

y-intercepts:

$$\left((0)^2 + y^2 - 0\right)^2 = (0)^2 + y^2$$

$$(y^2)^2 = y^2$$

$$y^4 = y^2$$

$$y^4 - y^2 = 0$$

$$y^2(y^2 - 1) = 0$$

$$y^2 = 0 \quad \text{or} \quad y^2 - 1 = 0$$

$$y = 0 \quad y^2 = 1$$

$$y = \pm 1$$

The intercepts are  $(0, 0)$ ,  $(2, 0)$ ,  $(0, -1)$ , and  $(0, 1)$ .

**b.** Test x-axis symmetry: Let  $y = -y$

$$(x^2 + (-y)^2 - x)^2 = x^2 + (-y)^2$$

$$(x^2 + y^2 - x)^2 = x^2 + y^2 \quad \text{same}$$

Test y-axis symmetry: Let  $x = -x$

$$\left((-x)^2 + y^2 - (-x)\right)^2 = (-x)^2 + y^2$$

$$(x^2 + y^2 + x)^2 = x^2 + y^2 \quad \text{different}$$

Test origin symmetry: Let  $x = -x$  and  $y = -y$

$$\left((-x)^2 + (-y)^2 - (-x)\right)^2 = (-x)^2 + (-y)^2$$

$$(x^2 + y^2 + x)^2 = x^2 + y^2 \quad \text{different}$$

Thus, the graph will have x-axis symmetry.

**86. a.**  $16y^2 = 120x - 225$

x-intercepts:

$$16y^2 = 120(0) - 225$$

$$16y^2 = -225$$

$$y^2 = -\frac{225}{16}$$

no real solution

y-intercepts:

$$16(0)^2 = 120x - 225$$

$$0 = 120x - 225$$

$$-120x = -225$$

$$x = \frac{-225}{-120} = \frac{15}{8}$$

The only intercept is  $\left(\frac{15}{8}, 0\right)$ .

**b.** Test x-axis symmetry: Let  $y = -y$

$$16(-y)^2 = 120x - 225$$

$$16y^2 = 120x - 225 \quad \text{same}$$

Test y-axis symmetry: Let  $x = -x$

$$16y^2 = 120(-x) - 225$$

$$16y^2 = -120x - 225 \quad \text{different}$$

Test origin symmetry: Let  $x = -x$  and  $y = -y$

$$16(-y)^2 = 120(-x) - 225$$

$$16y^2 = -120x - 225 \quad \text{different}$$

Thus, the graph will have x-axis symmetry.

**87.** Answers will vary. One example:

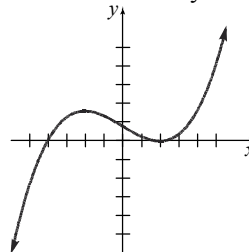

**88.** Answers will vary

**89.** Answers will vary.

Case 1: Graph has x-axis and y-axis symmetry, show origin symmetry.

$(x, y)$  on graph  $\rightarrow (x, -y)$  on graph

(from x-axis symmetry)

$(x, -y)$  on graph  $\rightarrow (-x, -y)$  on graph

(from y-axis symmetry)

Since the point  $(-x, -y)$  is also on the graph, the graph has origin symmetry.

Case 2: Graph has x-axis and origin symmetry, show y-axis symmetry.

## Chapter 1: Graphs

$(x, y)$  on graph  $\rightarrow (x, -y)$  on graph

(from  $x$ -axis symmetry)

$(x, -y)$  on graph  $\rightarrow (-x, y)$  on graph

(from origin symmetry)

Since the point  $(-x, y)$  is also on the graph, the graph has  $y$ -axis symmetry.

Case 3: Graph has  $y$ -axis and origin symmetry, show  $x$ -axis symmetry.

$(x, y)$  on graph  $\rightarrow (-x, y)$  on graph

(from  $y$ -axis symmetry)

$(-x, y)$  on graph  $\rightarrow (x, -y)$  on graph

(from origin symmetry)

Since the point  $(x, -y)$  is also on the graph, the graph has  $x$ -axis symmetry.

90. Answers may vary. The graph must contain the points  $(-2, 5)$ ,  $(-1, 3)$ , and  $(0, 2)$ . For the graph to be symmetric about the  $y$ -axis, the graph must also contain the points  $(2, 5)$  and  $(1, 3)$  (note that  $(0, 2)$  is on the  $y$ -axis).

For the graph to also be symmetric with respect to the  $x$ -axis, the graph must also contain the points  $(-2, -5)$ ,  $(-1, -3)$ ,  $(0, -2)$ ,  $(2, -5)$ , and  $(1, -3)$ . Recall that a graph with two of the symmetries ( $x$ -axis,  $y$ -axis, origin) will necessarily have the third. Therefore, if the original graph with  $y$ -axis symmetry also has  $x$ -axis symmetry, then it will also have origin symmetry.

## Section 1.3

$$\begin{aligned}
 1. \quad & 2x^2 + 5x + 2 = 0 \\
 & (2x+1)(x+2) = 0 \\
 & 2x+1=0 \quad \text{or} \quad x+2=0 \\
 & 2x=-1 \qquad \qquad x=-2 \\
 & x = -\frac{1}{2}
 \end{aligned}$$

The solution set is  $\left\{-2, -\frac{1}{2}\right\}$ .

$$\begin{aligned}
 2. \quad & 2x+3 = 4(x-1)+1 \\
 & 2x+3 = 4x-4+1 \\
 & 2x+3 = 4x-3 \\
 & -2x+3 = -3 \\
 & -2x = -6 \\
 & x = 3
 \end{aligned}$$

The solution set is  $\{3\}$ .

### 3. ZERO

4. False; exact solutions are obtained, in general, if the solution is a rational number. For irrational solutions, approximate answers are typically given, though some utilities can express certain irrational expressions in exact form.

5.  $x^3 - 4x + 2 = 0$ ; Use ZERO (or ROOT) on the graph of  $y_1 = x^3 - 4x + 2$ .

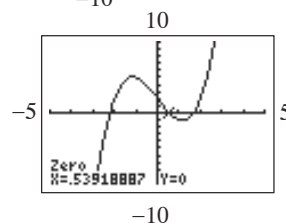
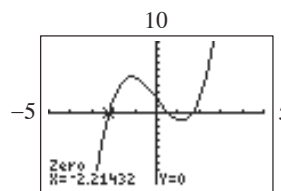



**Section 1.3: Solving Equations Using a Graphing Utility**

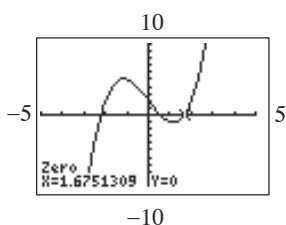

The solution set is  $\{-2.21, 0.54, 1.68\}$ .

6.  $x^3 - 8x + 1 = 0$ ; Use ZERO (or ROOT) on the graph of  $y_1 = x^3 - 8x + 1$ .

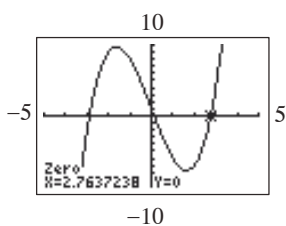
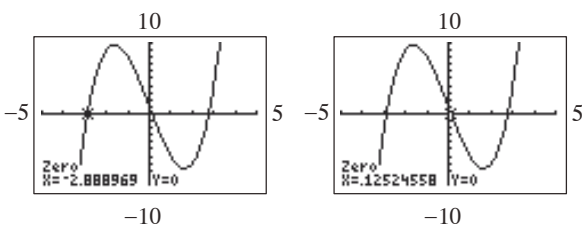

The solution set is  $\{-2.89, 0.13, 2.76\}$ .

7.  $-2x^4 + 5 = 3x - 2$ ; Use INTERSECT on the graphs of  $y_1 = -2x^4 + 5$  and  $y_2 = 3x - 2$ .

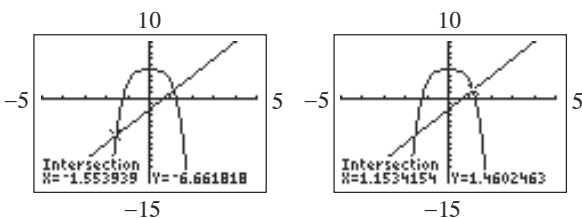

The solution set is  $\{-1.55, 1.15\}$ .

8.  $-x^4 + 1 = 2x^2 - 3$ ; Use INTERSECT on the graphs of  $y_1 = -x^4 + 1$  and  $y_2 = 2x^2 - 3$ .

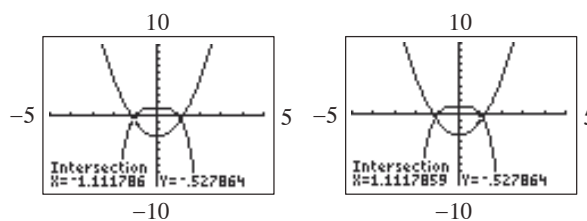

The solution set is  $\{-1.11, 1.11\}$ .

9.  $x^4 - 2x^3 + 3x - 1 = 0$ ; Use ZERO (or ROOT) on the graph of  $y_1 = x^4 - 2x^3 + 3x - 1$ .

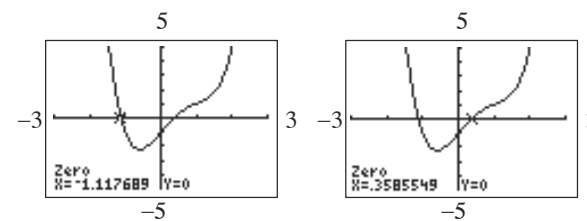

The solution set is  $\{-1.12, 0.36\}$ .

10.  $3x^4 - x^3 + 4x^2 - 5 = 0$ ; Use ZERO (or ROOT) on the graph of  $y_1 = 3x^4 - x^3 + 4x^2 - 5$ .

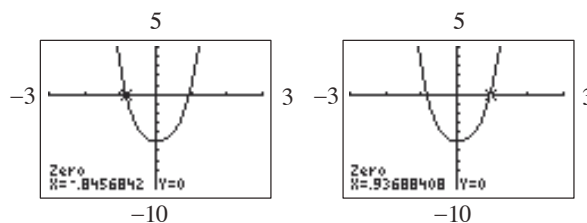

The solution set is  $\{-0.85, 0.94\}$ .

11.  $-x^3 - \frac{5}{3}x^2 + \frac{7}{2}x + 2 = 0$ ;

Use ZERO (or ROOT) on the graph of  $y_1 = -x^3 - (5/3)x^2 + (7/2)x + 2$ .

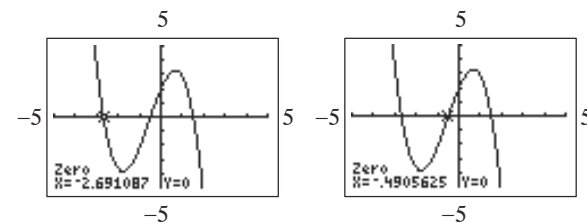

**Chapter 1: Graphs**

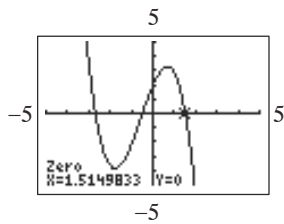

The solution set is  $\{-2.69, -0.49, 1.51\}$ .

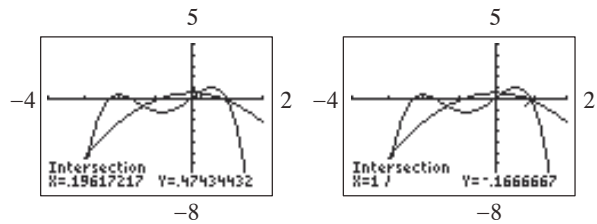

The solution set is  $\{-2.86, -1.34, 0.20, 1.00\}$ .

12.  $-x^4 + 3x^3 + \frac{7}{3}x^2 - \frac{15}{2}x + 2 = 0$ ; Use ZERO (or ROOT) on the graph of  $y_1 = -x^4 + 3x^3 + (7/3)x^2 - (15/2)x + 2$ .

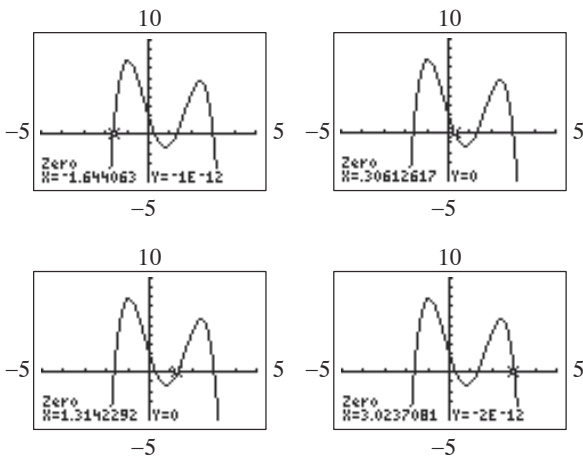

The solution set is  $\{-1.64, 0.31, 1.31, 3.02\}$ .

13.  $-\frac{2}{3}x^4 - 2x^3 + \frac{5}{2}x = -\frac{2}{3}x^2 + \frac{1}{2}$   
Use INTERSECT on the graphs of  $y_1 = -(2/3)x^4 - 2x^3 + (5/2)x$  and  $y_2 = -(2/3)x^2 + 1/2$ .

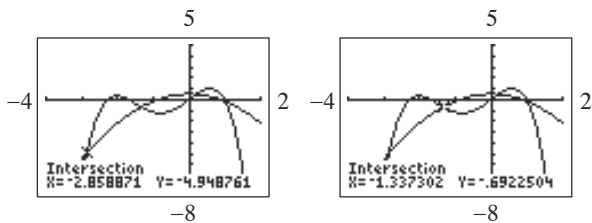

14.  $\frac{1}{4}x^3 - 5x = \frac{1}{5}x^2 - 4$   
Use INTERSECT on the graphs of  $y_1 = x^3/4 - 5x$  and  $y_2 = x^2/5 - 4$  and a standard viewing window (-10 to 10 for both x and y).

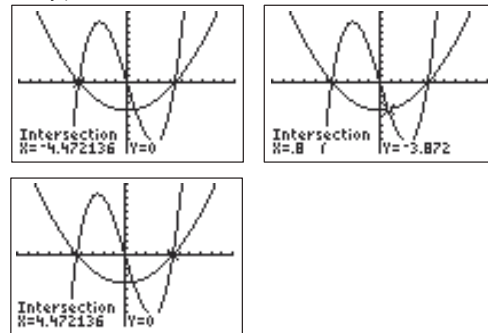

The solution set is  $\{-4.47, 0.80, 4.47\}$ .

15.  $x^4 - 5x^2 + 2x + 11 = 0$   
Use ZERO (or ROOT) on the graph of  $y_1 = x^4 - 5x^2 + 2x + 11$ .

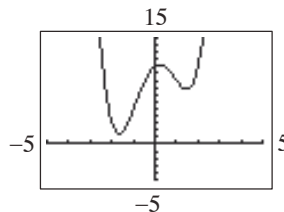

There are no real solutions.

16.  $-3x^4 + 8x^2 - 2x - 9 = 0$   
Use ZERO (or ROOT) on the graph of  $y_1 = -3x^4 + 8x^2 - 2x - 9$ .

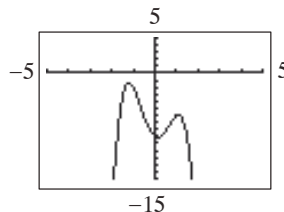

There are no real solutions.

**Section 1.3: Solving Equations Using a Graphing Utility**

17.  $2(3+2x) = 3(x-4)$   
 $6+4x = 3x-12$   
 $6+4x-6 = 3x-12-6$   
 $4x = 3x-18$   
 $4x-3x = 3x-18-3x$   
 $x = -18$   
 The solution set is  $\{-18\}$ .

18.  $3(2-x) = 2x-1$   
 $6-3x = 2x-1$   
 $6-3x-6 = 2x-1-6$   
 $-3x = 2x-7$   
 $-3x-2x = 2x-7-2x$   
 $-5x = -7$   
 $\frac{-5x}{-5} = \frac{-7}{-5}$   
 $x = \frac{7}{5}$   
 The solution set is  $\left\{\frac{7}{5}\right\}$ .

19.  $8x-(2x+1) = 3x-13$   
 $8x-2x-1 = 3x-13$   
 $6x-1 = 3x-13$   
 $6x-1+1 = 3x-13+1$   
 $6x = 3x-12$   
 $6x-3x = 3x-12-3x$   
 $3x = -12$   
 $\frac{3x}{3} = \frac{-12}{3}$   
 $x = -4$   
 The solution set is  $\{-4\}$ .

20.  $5-(2x-1) = 10-x$   
 $5-2x+1 = 10-x$   
 $-2x+6 = 10-x$   
 $-2x+6+2x = 10-x+2x$   
 $6 = 10+x$   
 $6-10 = 10+x-10$   
 $-4 = x$   
 The solution set is  $\{-4\}$ .

21.  $\frac{x+1}{3} + \frac{x+2}{7} = 5$   
 $21\left(\frac{x+1}{3}\right) + 21\left(\frac{x+2}{7}\right) = 21(5)$   
 $7x+7+3x+6 = 105$   
 $10x+13 = 105$   
 $10x+13-13 = 105-13$   
 $10x = 92$   
 $\frac{10x}{10} = \frac{92}{10}$   
 $x = \frac{46}{5}$   
 The solution set is  $\left\{\frac{46}{5}\right\}$ .

22.  $\frac{2x+1}{3} + 16 = 3x$   
 $3\left(\frac{2x+1}{3} + 16\right) = 3 \cdot 3x$   
 $2x+1+48 = 9x$   
 $2x+49 = 9x$   
 $2x+49-2x = 9x-2x$   
 $49 = 7x$   
 $\frac{49}{7} = \frac{7x}{7}$   
 $x = 7$   
 The solution set is  $\{7\}$ .

23.  $\frac{5}{y} + \frac{4}{y} = 3$   
 $\frac{9}{y} = 3$   
 $\left(\frac{9}{y}\right)^{-1} = 3^{-1}$   
 $\frac{y}{9} = \frac{1}{3}$   
 $9 \cdot \frac{y}{9} = 9 \cdot \frac{1}{3}$   
 $y = 3$   
 The solution set is  $\{3\}$ .

**Chapter 1: Graphs**

$$\begin{aligned}
 24. \quad \frac{4}{y} - 5 &= \frac{18}{2y} \\
 2y\left(\frac{4}{y} - 5\right) &= 2y\left(\frac{18}{2y}\right) \\
 8 - 10y &= 18 \\
 8 - 10y - 8 &= 18 - 8 \\
 -10y &= 10 \\
 \frac{-10y}{-10} &= \frac{10}{-10} \\
 y &= -1
 \end{aligned}$$

The solution set is  $\{-1\}$ .

$$\begin{aligned}
 25. \quad (x+7)(x-1) &= (x+1)^2 \\
 x^2 - x + 7x - 7 &= x^2 + 2x + 1 \\
 x^2 + 6x - 7 &= x^2 + 2x + 1 \\
 x^2 + 6x - 7 - x^2 &= x^2 + 2x + 1 - x^2 \\
 6x - 7 &= 2x + 1 \\
 6x - 7 - 2x &= 2x + 1 - 2x \\
 4x - 7 &= 1 \\
 4x - 7 + 7 &= 1 + 7 \\
 4x &= 8 \\
 \frac{4x}{4} &= \frac{8}{4} \Rightarrow x = 2
 \end{aligned}$$

The solution set is  $\{2\}$ .

$$\begin{aligned}
 26. \quad (x+2)(x-3) &= (x-3)^2 \\
 x^2 + 2x - 3x - 6 &= x^2 - 6x + 9 \\
 x^2 - x - 6 &= x^2 - 6x + 9 \\
 x^2 - x - 6 - x^2 &= x^2 - 6x + 9 - x^2 \\
 -x - 6 &= -6x + 9 \\
 -x - 6 + 6x &= -6x + 9 + 6x \\
 5x - 6 &= 9 \\
 5x - 6 + 6 &= 9 + 6 \\
 5x &= 15 \\
 \frac{5x}{5} &= \frac{15}{5} \\
 x &= 3
 \end{aligned}$$

The solution set is  $\{3\}$ .

$$\begin{aligned}
 27. \quad x^2 - 3x - 28 &= 0 \\
 (x-7)(x+4) &= 28 \\
 x-7 = 0 \quad \text{or} \quad x+4 = 0 \\
 x = 7 \quad \quad \quad x = -4 \\
 \text{The solution set is } &\{-4, 7\}.
 \end{aligned}$$

$$\begin{aligned}
 28. \quad x^2 - 7x - 18 &= 0 \\
 (x-9)(x+2) &= 0 \\
 x-9 = 0 \quad \text{or} \quad x+2 = 0 \\
 x = 9 \quad \quad \quad x = -2 \\
 \text{The solution set is } &\{-2, 9\}.
 \end{aligned}$$

$$\begin{aligned}
 29. \quad 3x^2 &= 4x + 4 \\
 3x^2 - 4x - 4 &= 0 \\
 (3x+2)(x-2) &= 0 \\
 3x+2 = 0 \quad \text{or} \quad x-2 = 0 \\
 3x = -2 \quad \quad \quad x = 2 \\
 x &= -\frac{2}{3} \\
 \text{The solution set is } &\left\{-\frac{2}{3}, 2\right\}.
 \end{aligned}$$

$$\begin{aligned}
 30. \quad 5x^2 &= 13x + 6 \\
 5x^2 - 13x - 6 &= 0 \\
 (5x+2)(x-3) &= 0 \\
 5x+2 = 0 \quad \text{or} \quad x-3 = 0 \\
 5x = -2 \quad \quad \quad x = 3 \\
 x &= -\frac{2}{5} \\
 \text{The solution set is } &\left\{-\frac{2}{5}, 3\right\}.
 \end{aligned}$$

$$\begin{aligned}
 31. \quad x^3 + x^2 - 4x - 4 &= 0 \\
 (x^3 + x^2) + (-4x - 4) &= 0 \\
 x^2(x+1) - 4(x+1) &= 0 \\
 (x+1)(x^2 - 4) &= 0 \\
 (x+1)(x-2)(x+2) &= 0 \\
 x+1 = 0 \quad \text{or} \quad x-2 = 0 \quad \text{or} \quad x+2 = 0 \\
 x = -1 \quad \quad \quad x = 2 \quad \quad \quad x = -2 \\
 \text{The solution set is } &\{-2, -1, 2\}.
 \end{aligned}$$

**Section 1.3: Solving Equations Using a Graphing Utility**

32.  $x^3 + 2x^2 - 9x - 18 = 0$   
 $(x^3 + 2x^2) + (-9x - 18) = 0$   
 $x^2(x + 2) - 9(x + 2) = 0$   
 $(x + 2)(x^2 - 9) = 0$   
 $(x + 2)(x - 3)(x + 3) = 0$   
 $x + 2 = 0$  or  $x - 3 = 0$  or  $x + 3 = 0$   
 $x = -2$        $x = 3$        $x = -3$   
 The solution set is  $\{-3, -2, 3\}$ .

33.  $\sqrt{x+1} = 4$   
 $(\sqrt{x+1})^2 = 4^2$   
 $x + 1 = 16$   
 $x + 1 - 1 = 16 - 1$   
 $x = 15$

Check:

$$\sqrt{15+1} = 4$$

$$\sqrt{16} = 4$$

$$4 = 4 \quad \top$$

The solution set is  $\{15\}$ .

34.  $\sqrt{x-2} = 3$   
 $(\sqrt{x-2})^2 = 3^2$   
 $x - 2 = 9$   
 $x - 2 + 2 = 9 + 2$   
 $x = 11$

Check:

$$\sqrt{11-2} = 3$$

$$\sqrt{9} = 3$$

$$3 = 3 \quad \top$$

The solution set is  $\{11\}$ .

35.  $\frac{2}{x+2} + \frac{3}{x-1} = \frac{-8}{5}$   
 LCD =  $5(x-1)(x+2)$

Multiply both sides of the equation by the LCD.  
 This yields the equation

$$2 \cdot 5(x-1) + 3 \cdot 5(x+2) = -8(x-1)(x+2)$$

$$10(x-1) + 15(x+2) = -8(x^2 + x - 2)$$

$$10x - 10 + 15x + 30 = -8x^2 - 8x + 16$$

$$25x + 20 = -8x^2 - 8x + 16$$

$$8x^2 + 33x + 4 = 0$$

$$(8x+1)(x+4) = 0$$

$$8x+1 = 0 \quad \text{or} \quad x+4 = 0$$

$$8x = -1 \quad \quad \quad x = -4$$

$$x = -\frac{1}{8}$$

The solution set is  $\left\{-4, -\frac{1}{8}\right\}$ .

36.  $\frac{1}{x+1} - \frac{5}{x-4} = \frac{21}{4}$

$$\text{LCD} = 4(x-4)(x+1)$$

Multiply both sides of the equation by the LCD.

This gives the equation

$$4(x-4) - 5 \cdot 4(x+1) = 21(x-4)(x+1)$$

$$4(x-4) - 20(x+1) = 21(x^2 - 3x - 4)$$

$$4x - 16 - 20x - 20 = 21x^2 - 63x - 84$$

$$-16x - 36 = 21x^2 - 63x - 84$$

$$0 = 21x^2 - 47x - 48$$

$$0 = (x-3)(21x+16)$$

$$x-3 = 0 \quad \text{or} \quad 21x+16 = 0$$

$$x = 3 \quad \quad \quad 21x = -16$$

$$x = -\frac{16}{21}$$

The solution set is  $\left\{-\frac{16}{21}, 3\right\}$ .

**Chapter 1: Graphs**

**Section 1.4**

1. undefined; 0

2. 3; 2

x-intercept:  $2x + 3(0) = 6$

$$2x = 6$$

$$x = 3$$

y-intercept:  $2(0) + 3y = 6$

$$3y = 6$$

$$y = 2$$

3. True

4. False; the slope is  $\frac{3}{2}$ .

$$2y = 3x + 5$$

$$y = \frac{3}{2}x + \frac{5}{2}$$

5. True;  $2(1) + (2) = 4$

$$2 + 2 = 4$$

$$4 = 4 \text{ True}$$

6.  $m_1 = m_2$ ; y-intercepts;  $m_1 \cdot m_2 = -1$

7. 2

8.  $-\frac{1}{2}$

9. False; perpendicular lines have slopes that are opposite-reciprocals of each other.

10. d

11. c

12. b

13. a. Slope =  $\frac{1-0}{2-0} = \frac{1}{2}$

b. If  $x$  increases by 2 units,  $y$  will increase by 1 unit.

14. a. Slope =  $\frac{1-0}{-2-0} = -\frac{1}{2}$

b. If  $x$  increases by 2 units,  $y$  will decrease by 1 unit.

15. a. Slope =  $\frac{1-2}{1-(-2)} = -\frac{1}{3}$

b. If  $x$  increases by 3 units,  $y$  will decrease by 1 unit.

16. a. Slope =  $\frac{2-1}{2-(-1)} = \frac{1}{3}$

b. If  $x$  increases by 3 units,  $y$  will increase by 1 unit.

17. Slope =  $\frac{y_2 - y_1}{x_2 - x_1} = \frac{0-3}{4-2} = -\frac{3}{2}$

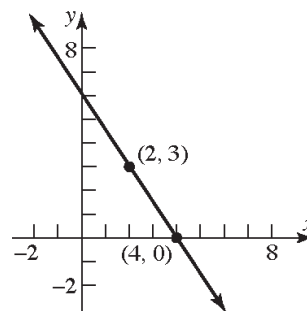

18. Slope =  $\frac{y_2 - y_1}{x_2 - x_1} = \frac{4-2}{3-4} = \frac{2}{-1} = -2$

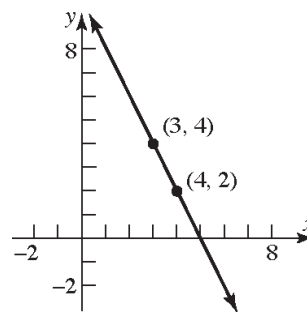

19. Slope =  $\frac{y_2 - y_1}{x_2 - x_1} = \frac{1-3}{2-(-2)} = \frac{-2}{4} = -\frac{1}{2}$

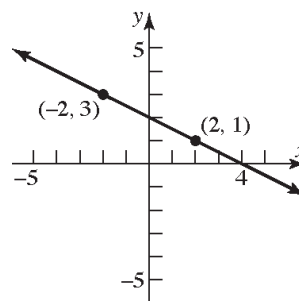

20. Slope =  $\frac{y_2 - y_1}{x_2 - x_1} = \frac{3 - 1}{2 - (-1)} = \frac{2}{3}$

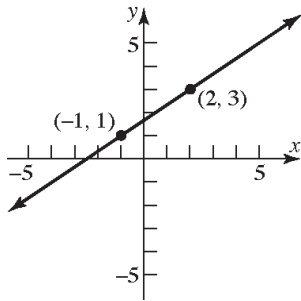

24. Slope =  $\frac{y_2 - y_1}{x_2 - x_1} = \frac{2 - 0}{2 - 2} = \frac{2}{0}$  undefined.

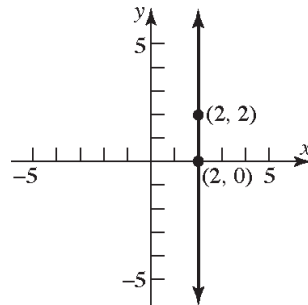

21. Slope =  $\frac{y_2 - y_1}{x_2 - x_1} = \frac{-1 - (-1)}{2 - (-3)} = \frac{0}{5} = 0$

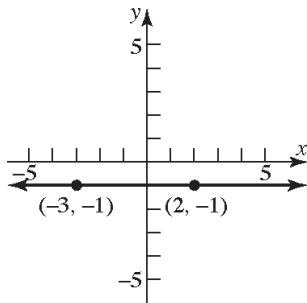

25.  $P = (1, 2); m = 3$

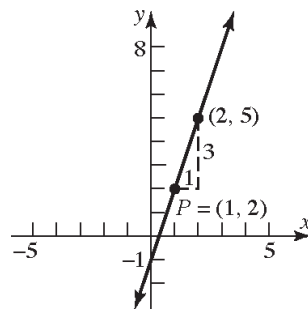

22. Slope =  $\frac{y_2 - y_1}{x_2 - x_1} = \frac{2 - 2}{-5 - 4} = \frac{0}{-9} = 0$

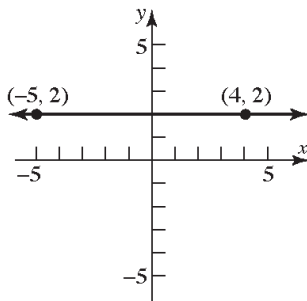

26.  $P = (2, 1); m = 4$

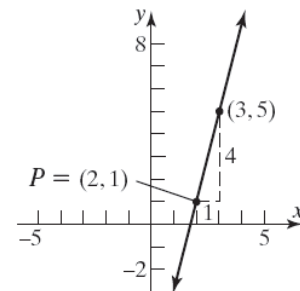

23. Slope =  $\frac{y_2 - y_1}{x_2 - x_1} = \frac{-2 - 2}{-1 - (-1)} = \frac{-4}{0}$  undefined.

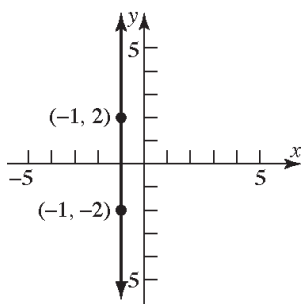

27.  $P = (2, 4); m = -\frac{3}{4}$

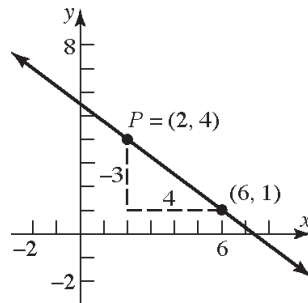

**Chapter 1: Graphs**

28.  $P = (1, 3); m = -\frac{2}{5}$

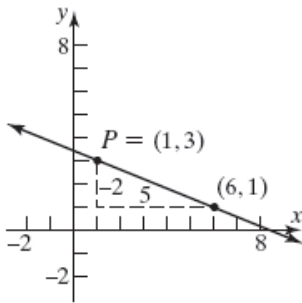

29.  $P = (-1, 3); m = 0$

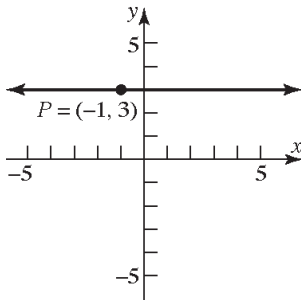

30.  $P = (2, -4); m = 0$

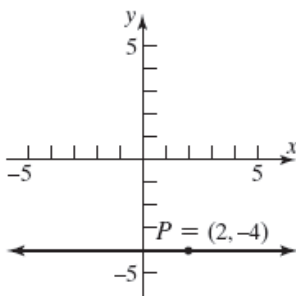

31.  $P = (0, 3);$  slope undefined

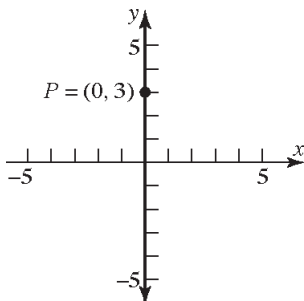

(note: the line is the y-axis)

32.  $P = (-2, 0);$  slope undefined

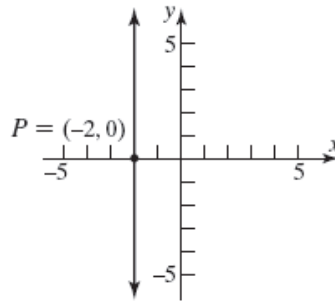

33. Slope  $= 4 = \frac{4}{1}$ ; point:  $(1, 2)$

If  $x$  increases by 1 unit, then  $y$  increases by 4 units.

Answers will vary. Three possible points are:

$x = 1 + 1 = 2$  and  $y = 2 + 4 = 6$

$(2, 6)$

$x = 2 + 1 = 3$  and  $y = 6 + 4 = 10$

$(3, 10)$

$x = 3 + 1 = 4$  and  $y = 10 + 4 = 14$

$(4, 14)$

34. Slope  $= 2 = \frac{2}{1}$ ; point:  $(-2, 3)$

If  $x$  increases by 1 unit, then  $y$  increases by 2 units.

Answers will vary. Three possible points are:

$x = -2 + 1 = -1$  and  $y = 3 + 2 = 5$

$(-1, 5)$

$x = -1 + 1 = 0$  and  $y = 5 + 2 = 7$

$(0, 7)$

$x = 0 + 1 = 1$  and  $y = 7 + 2 = 9$

$(1, 9)$

35. Slope  $= -\frac{3}{2} = \frac{-3}{2}$ ; point:  $(2, -4)$

If  $x$  increases by 2 units, then  $y$  decreases by 3 units.

Answers will vary. Three possible points are:

$x = 2 + 2 = 4$  and  $y = -4 - 3 = -7$

$(4, -7)$

$x = 4 + 2 = 6$  and  $y = -7 - 3 = -10$

$(6, -10)$

$x = 6 + 2 = 8$  and  $y = -10 - 3 = -13$

$(8, -13)$



36. Slope =  $\frac{4}{3}$ ; point:  $(-3, 2)$

If  $x$  increases by 3 units, then  $y$  increases by 4 units.

Answers will vary. Three possible points are:

$$x = -3 + 3 = 0 \text{ and } y = 2 + 4 = 6$$

$$(0, 6)$$

$$x = 0 + 3 = 3 \text{ and } y = 6 + 4 = 10$$

$$(3, 10)$$

$$x = 3 + 3 = 6 \text{ and } y = 10 + 4 = 14$$

$$(6, 14)$$

37. Slope =  $-2 = \frac{-2}{1}$ ; point:  $(-2, -3)$

If  $x$  increases by 1 unit, then  $y$  decreases by 2 units.

Answers will vary. Three possible points are:

$$x = -2 + 1 = -1 \text{ and } y = -3 - 2 = -5$$

$$(-1, -5)$$

$$x = -1 + 1 = 0 \text{ and } y = -5 - 2 = -7$$

$$(0, -7)$$

$$x = 0 + 1 = 1 \text{ and } y = -7 - 2 = -9$$

$$(1, -9)$$

38. Slope =  $-1 = \frac{-1}{1}$ ; point:  $(4, 1)$

If  $x$  increases by 1 unit, then  $y$  decreases by 1 unit.

Answers will vary. Three possible points are:

$$x = 4 + 1 = 5 \text{ and } y = 1 - 1 = 0$$

$$(5, 0)$$

$$x = 5 + 1 = 6 \text{ and } y = 0 - 1 = -1$$

$$(6, -1)$$

$$x = 6 + 1 = 7 \text{ and } y = -1 - 1 = -2$$

$$(7, -2)$$

39.  $(0, 0)$  and  $(2, 1)$  are points on the line.

$$\text{Slope} = \frac{1-0}{2-0} = \frac{1}{2}$$

$y$ -intercept is 0; using  $y = mx + b$ :

$$y = \frac{1}{2}x + 0$$

$$2y = x$$

$$0 = x - 2y$$

$$x - 2y = 0 \text{ or } y = \frac{1}{2}x$$

40.  $(0, 0)$  and  $(-2, 1)$  are points on the line.

$$\text{Slope} = \frac{1-0}{-2-0} = \frac{1}{-2} = -\frac{1}{2}$$

$y$ -intercept is 0; using  $y = mx + b$ :

$$y = -\frac{1}{2}x + 0$$

$$2y = -x$$

$$x + 2y = 0$$

$$x + 2y = 0 \text{ or } y = -\frac{1}{2}x$$

41.  $(-1, 3)$  and  $(1, 1)$  are points on the line.

$$\text{Slope} = \frac{1-3}{1-(-1)} = \frac{-2}{2} = -1$$

Using  $y - y_1 = m(x - x_1)$

$$y - 1 = -1(x - 1)$$

$$y - 1 = -x + 1$$

$$y = -x + 2$$

$$x + y = 2 \text{ or } y = -x + 2$$

42.  $(-1, 1)$  and  $(2, 2)$  are points on the line.

$$\text{Slope} = \frac{2-1}{2-(-1)} = \frac{1}{3}$$

Using  $y - y_1 = m(x - x_1)$

$$y - 1 = \frac{1}{3}(x - (-1))$$

$$y - 1 = \frac{1}{3}(x + 1)$$

$$y - 1 = \frac{1}{3}x + \frac{1}{3}$$

$$y = \frac{1}{3}x + \frac{4}{3}$$

$$x - 3y = -4 \text{ or } y = \frac{1}{3}x + \frac{4}{3}$$

43.  $y - y_1 = m(x - x_1)$ ,  $m = 2$

$$y - 3 = 2(x - 3)$$

$$y - 3 = 2x - 6$$

$$y = 2x - 3$$

$$2x - y = 3 \text{ or } y = 2x - 3$$

44.  $y - y_1 = m(x - x_1)$ ,  $m = -1$

$$y - 2 = -1(x - 1)$$

$$y - 2 = -x + 1$$

$$y = -x + 3$$

$$x + y = 3 \text{ or } y = -x + 3$$

**Chapter 1: Graphs**

45.  $y - y_1 = m(x - x_1)$ ,  $m = -\frac{1}{2}$

$$y - 2 = -\frac{1}{2}(x - 1)$$

$$y - 2 = -\frac{1}{2}x + \frac{1}{2}$$

$$y = -\frac{1}{2}x + \frac{5}{2}$$

$$x + 2y = 5 \text{ or } y = -\frac{1}{2}x + \frac{5}{2}$$

46.  $y - y_1 = m(x - x_1)$ ,  $m = 1$

$$y - 1 = 1(x - (-1))$$

$$y - 1 = x + 1$$

$$y = x + 2$$

$$x - y = -2 \text{ or } y = x + 2$$

47. Slope = 3; containing  $(-2, 3)$

$$y - y_1 = m(x - x_1)$$

$$y - 3 = 3(x - (-2))$$

$$y - 3 = 3x + 6$$

$$y = 3x + 9$$

$$3x - y = -9 \text{ or } y = 3x + 9$$

48. Slope = 2; containing the point  $(4, -3)$

$$y - y_1 = m(x - x_1)$$

$$y - (-3) = 2(x - 4)$$

$$y + 3 = 2x - 8$$

$$y = 2x - 11$$

$$2x - y = 11 \text{ or } y = 2x - 11$$

49. Slope =  $-\frac{2}{3}$ ; containing  $(1, -1)$

$$y - y_1 = m(x - x_1)$$

$$y - (-1) = -\frac{2}{3}(x - 1)$$

$$y + 1 = -\frac{2}{3}x + \frac{2}{3}$$

$$y = -\frac{2}{3}x - \frac{1}{3}$$

$$2x + 3y = -1 \text{ or } y = -\frac{2}{3}x - \frac{1}{3}$$

50. Slope =  $\frac{1}{2}$ ; containing the point  $(3, 1)$

$$y - y_1 = m(x - x_1)$$

$$y - 1 = \frac{1}{2}(x - 3)$$

$$y - 1 = \frac{1}{2}x - \frac{3}{2}$$

$$y = \frac{1}{2}x - \frac{1}{2}$$

$$x - 2y = 1 \text{ or } y = \frac{1}{2}x - \frac{1}{2}$$

51. Slope =  $-3$ ; y-intercept = 3

$$y = mx + b$$

$$y = -3x + 3$$

$$3x + y = 3 \text{ or } y = -3x + 3$$

52. Slope =  $-5$ ; y-intercept =  $-7$

$$y = mx + b$$

$$y = -5x + (-7)$$

$$5x + y = -7 \text{ or } y = -5x - 7$$

53. Containing  $(1, 3)$  and  $(-1, 2)$

$$m = \frac{2 - 3}{-1 - 1} = \frac{-1}{-2} = \frac{1}{2}$$

$$y - y_1 = m(x - x_1)$$

$$y - 3 = \frac{1}{2}(x - 1)$$

$$y - 3 = \frac{1}{2}x - \frac{1}{2}$$

$$y = \frac{1}{2}x + \frac{5}{2}$$

$$x - 2y = -5 \text{ or } y = \frac{1}{2}x + \frac{5}{2}$$

54. Containing the points  $(-3, 4)$  and  $(2, 5)$

$$m = \frac{5 - 4}{2 - (-3)} = \frac{1}{5}$$

$$y - y_1 = m(x - x_1)$$

$$y - 5 = \frac{1}{5}(x - 2)$$

$$y - 5 = \frac{1}{5}x - \frac{2}{5}$$

$$y = \frac{1}{5}x + \frac{23}{5}$$

$$x - 5y = -23 \text{ or } y = \frac{1}{5}x + \frac{23}{5}$$

55.  $x$ -intercept = 2;  $y$ -intercept = -1  
Points are (2,0) and (0,-1)  

$$m = \frac{-1-0}{0-2} = \frac{-1}{-2} = \frac{1}{2}$$

$$y = mx + b$$

$$y = \frac{1}{2}x - 1$$

$$x - 2y = 2 \text{ or } y = \frac{1}{2}x - 1$$
56.  $x$ -intercept = -4;  $y$ -intercept = 4  
Points are (-4, 0) and (0, 4)  

$$m = \frac{4-0}{0-(-4)} = \frac{4}{4} = 1$$

$$y = mx + b$$

$$y = 1x + 4$$

$$y = x + 4$$

$$x - y = -4 \text{ or } y = x + 4$$
57. Slope undefined; containing the point (2, 4)  
This is a vertical line.  
 $x = 2$  No slope-intercept form.
58. Slope undefined; containing the point (3, 8)  
This is a vertical line.  
 $x = 3$  No slope-intercept form.
59. Horizontal lines have slope  $m = 0$  and take the form  $y = b$ . Therefore, the horizontal line passing through the point (-3, 2) is  $y = 2$ .
60. Vertical lines have an undefined slope and take the form  $x = a$ . Therefore, the vertical line passing through the point (4, -5) is  $x = 4$ .
61. Parallel to  $y = 4x$ ; Slope = 4  
Containing (-1, 2)  

$$y - y_1 = m(x - x_1)$$

$$y - 2 = 4(x - (-1))$$

$$y - 2 = x + 4 \rightarrow y = 4x + 6$$

$$4x - y = -6 \text{ or } y = 4x + 6$$
62. Parallel to  $y = -3x$ ; Slope = -3; Containing the point (-1, 2)  

$$y - y_1 = m(x - x_1)$$

$$y - 2 = -3(x - (-1))$$

$$y - 2 = -3x - 3 \rightarrow y = -3x - 1$$

$$3x + y = -1 \text{ or } y = -3x - 1$$
63. Parallel to  $5x - y = -2$ ; Slope = 5  
Containing the point (0, 0)  

$$y - y_1 = m(x - x_1)$$

$$y - 0 = 5(x - 0)$$

$$y = 5x$$

$$5x - y = 0 \text{ or } y = 5x$$
64. Parallel to  $x - 2y = -5$ ;  
Slope =  $\frac{1}{2}$ ; Containing the point (0, 0)  

$$y - y_1 = m(x - x_1)$$

$$y - 0 = \frac{1}{2}(x - 0) \rightarrow y = \frac{1}{2}x$$

$$x - 2y = 0 \text{ or } y = \frac{1}{2}x$$
65. Parallel to  $x = 5$ ; Containing (4, 2)  
This is a vertical line.  
 $x = 4$  No slope-intercept form.
66. Parallel to  $y = 5$ ; Containing the point (4, 2)  
This is a horizontal line. Slope = 0  
 $y = 2$
67. Perpendicular to  $y = \frac{1}{6}x + 4$ ; Containing (1, -2)  
Slope of perpendicular = -6  

$$y - y_1 = m(x - x_1)$$

$$y - (-2) = -6(x - 1)$$

$$y + 2 = -6x + 6 \rightarrow y = -6x + 4$$

$$6x + y = 4 \text{ or } y = -6x + 4$$
68. Perpendicular to  $y = 8x - 3$ ; Containing the point (10, -2)  
Slope of perpendicular =  $-\frac{1}{8}$   

$$y - y_1 = m(x - x_1)$$

$$y - (-2) = -\frac{1}{8}(x - 10)$$

$$y + 2 = -\frac{1}{8}x + \frac{5}{4} \rightarrow y = -\frac{1}{8}x - \frac{3}{4}$$

$$x + 8y = -6 \text{ or } y = -\frac{1}{8}x - \frac{3}{4}$$

**Chapter 1: Graphs**

69. Perpendicular to  $2x + 5y = 2$ ; Containing the point  $(-3, -6)$

Slope of perpendicular =  $\frac{5}{2}$

$$y - y_1 = m(x - x_1)$$

$$y - (-6) = \frac{5}{2}(x - (-3)) \rightarrow y + 6 = \frac{5}{2}x + \frac{15}{2}$$

$$y = \frac{5}{2}x + \frac{3}{2}$$

$$5x - 2y = -3 \text{ or } y = \frac{5}{2}x + \frac{3}{2}$$

70. Perpendicular to  $x - 3y = -12$ ; Containing the point  $(0, 4)$

Slope of perpendicular =  $-3$

$$y = mx + b$$

$$y = -3x + 4$$

$$3x + y = 4 \text{ or } y = -3x + 4$$

71. Perpendicular to  $x = 8$ ; Containing  $(3, 4)$   
Slope of perpendicular = 0 (horizontal line)  
 $y = 4$

72. Perpendicular to  $y = 8$ ;  
Containing the point  $(3, 4)$   
Slope of perpendicular is undefined (vertical line).  $x = 3$  No slope-intercept form.

73.  $y = 2x + 3$ ; Slope = 2; y-intercept = 3

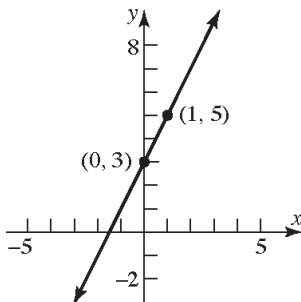

74.  $y = -3x + 4$ ; Slope =  $-3$ ; y-intercept = 4

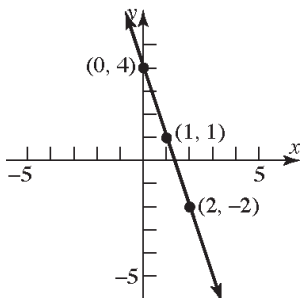

75.  $\frac{1}{4}y = x - 1$ ;  $y = 4x - 4$   
Slope = 4; y-intercept =  $-4$

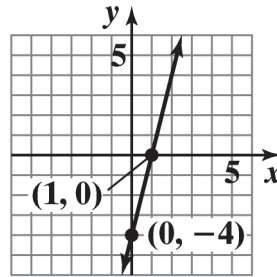

76.  $\frac{1}{3}x + y = 2$ ;  $y = -\frac{1}{3}x + 2$   
Slope =  $-\frac{1}{3}$ ; y-intercept = 2

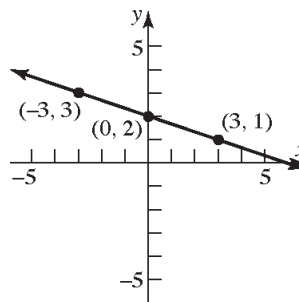

77.  $y = \frac{1}{2}x + 2$ ; Slope =  $\frac{1}{2}$ ; y-intercept = 2

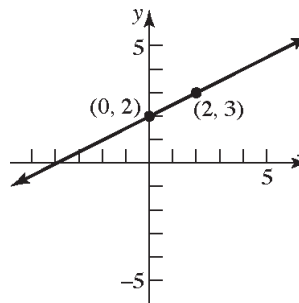

78.  $y = 2x + \frac{1}{2}$ ; Slope = 2; y-intercept =  $\frac{1}{2}$

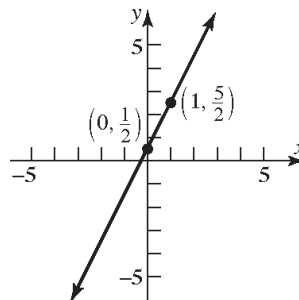

**Section 1.4: Lines**

79.  $x + 4y = 4$ ;  $4y = -x + 4 \rightarrow y = -\frac{1}{4}x + 1$

Slope =  $-\frac{1}{4}$ ; y-intercept = 1

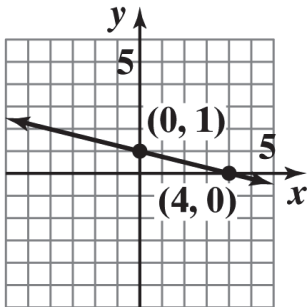

82.  $3x + 2y = 6$ ;  $2y = -3x + 6 \rightarrow y = -\frac{3}{2}x + 3$

Slope =  $-\frac{3}{2}$ ; y-intercept = 3

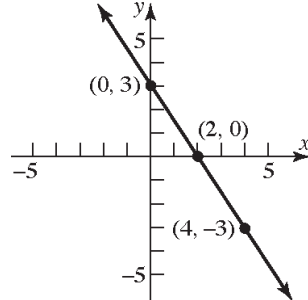

80.  $-x + 3y = 6$ ;  $3y = x + 6 \rightarrow y = \frac{1}{3}x + 2$

Slope =  $\frac{1}{3}$ ; y-intercept = 2

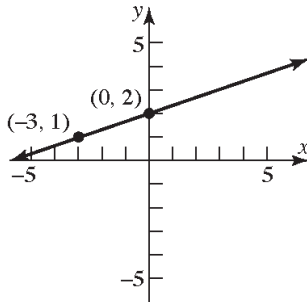

83.  $x + y = 1$ ;  $y = -x + 1$

Slope = -1; y-intercept = 1

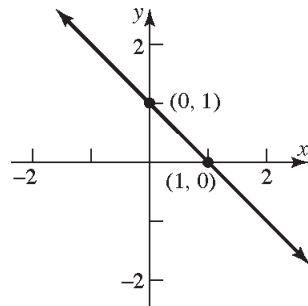

81.  $2x - 3y = 6$ ;  $-3y = -2x + 6 \rightarrow y = \frac{2}{3}x - 2$

Slope =  $\frac{2}{3}$ ; y-intercept = -2

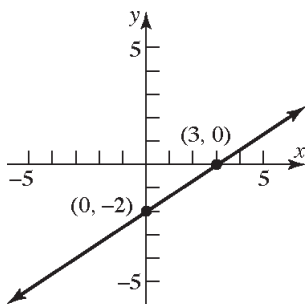

84.  $x - y = 2$ ;  $y = x - 2$

Slope = 1; y-intercept = -2

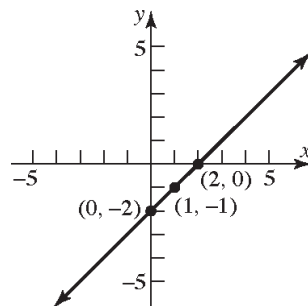

85.  $x = -4$ ; Slope is undefined  
y-intercept - none

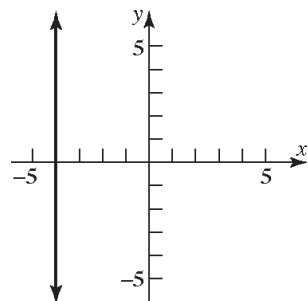

**Chapter 1: Graphs**

86.  $y = -1$ ; Slope = 0; y-intercept = -1

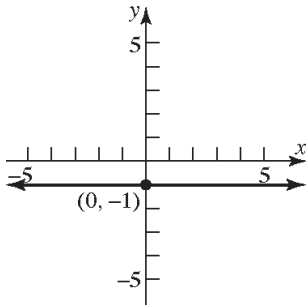

87.  $y = 5$ ; Slope = 0; y-intercept = 5

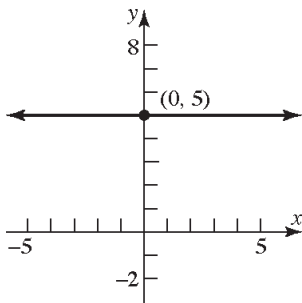

88.  $x = 2$ ; Slope is undefined  
y-intercept - none

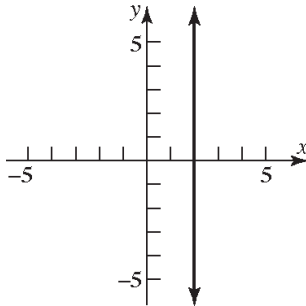

89.  $y - x = 0$ ;  $y = x$   
Slope = 1; y-intercept = 0

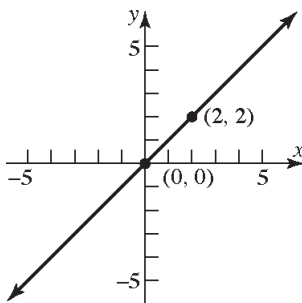

90.  $x + y = 0$ ;  $y = -x$   
Slope = -1; y-intercept = 0

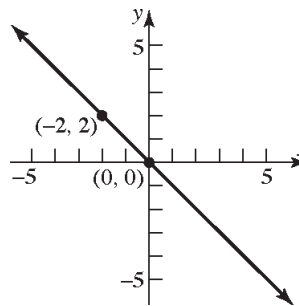

91.  $2y - 3x = 0$ ;  $2y = 3x \rightarrow y = \frac{3}{2}x$   
Slope =  $\frac{3}{2}$ ; y-intercept = 0

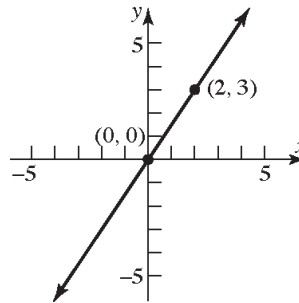

92.  $3x + 2y = 0$ ;  $2y = -3x \rightarrow y = -\frac{3}{2}x$   
Slope =  $-\frac{3}{2}$ ; y-intercept = 0

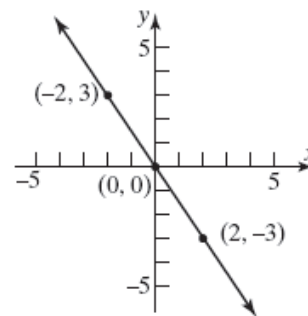

**Section 1.4: Lines**

**93. a.**  $x$ -intercept:  $2x + 3(0) = 6$

$$2x = 6$$

$$x = 3$$

The point  $(3, 0)$  is on the graph.

$y$ -intercept:  $2(0) + 3y = 6$

$$3y = 6$$

$$y = 2$$

The point  $(0, 2)$  is on the graph.

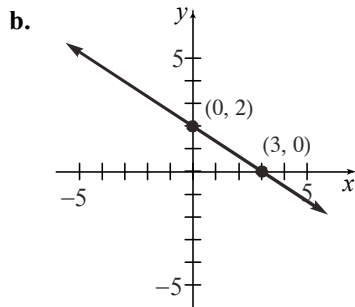

**94. a.**  $x$ -intercept:  $3x - 2(0) = 6$

$$3x = 6$$

$$x = 2$$

The point  $(2, 0)$  is on the graph.

$y$ -intercept:  $3(0) - 2y = 6$

$$-2y = 6$$

$$y = -3$$

The point  $(0, -3)$  is on the graph.

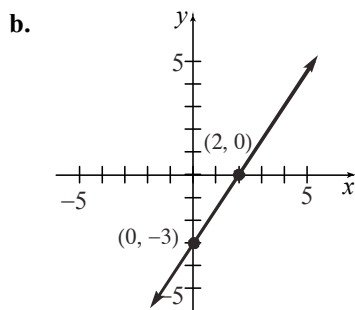

**95. a.**  $x$ -intercept:  $-4x + 5(0) = 40$

$$-4x = 40$$

$$x = -10$$

The point  $(-10, 0)$  is on the graph.

$y$ -intercept:  $-4(0) + 5y = 40$

$$5y = 40$$

$$y = 8$$

The point  $(0, 8)$  is on the graph.

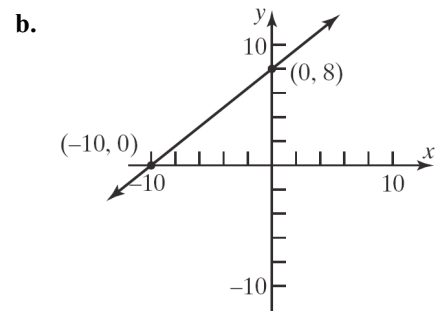

**96. a.**  $x$ -intercept:  $6x - 4(0) = 24$

$$6x = 24$$

$$x = 4$$

The point  $(4, 0)$  is on the graph.

$y$ -intercept:  $6(0) - 4y = 24$

$$-4y = 24$$

$$y = -6$$

The point  $(0, -6)$  is on the graph.

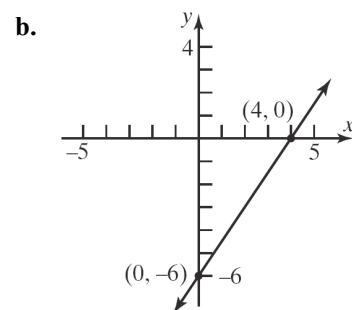

**Chapter 1: Graphs**

97. a.  $x$ -intercept:  $7x + 2(0) = 21$   
 $7x = 21$   
 $x = 3$

The point  $(3, 0)$  is on the graph.

$y$ -intercept:  $7(0) + 2y = 21$   
 $2y = 21$   
 $y = \frac{21}{2}$

The point  $(0, \frac{21}{2})$  is on the graph.

b.

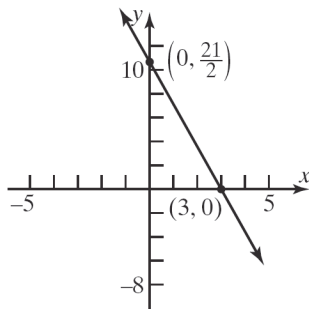

98. a.  $x$ -intercept:  $5x + 3(0) = 18$   
 $5x = 18$   
 $x = \frac{18}{5}$

The point  $(\frac{18}{5}, 0)$  is on the graph.

$y$ -intercept:  $5(0) + 3y = 18$   
 $3y = 18$   
 $y = 6$

The point  $(0, 6)$  is on the graph.

b.

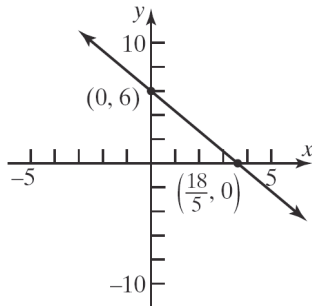

99. a.  $x$ -intercept:  $\frac{1}{2}x + \frac{1}{3}(0) = 1$   
 $\frac{1}{2}x = 1$   
 $x = 2$

The point  $(2, 0)$  is on the graph.

$y$ -intercept:  $\frac{1}{2}(0) + \frac{1}{3}y = 1$   
 $\frac{1}{3}y = 1$   
 $y = 3$

The point  $(0, 3)$  is on the graph.

b.

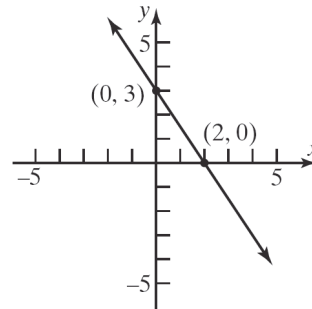

100. a.  $x$ -intercept:  $x - \frac{2}{3}(0) = 4$   
 $x = 4$

The point  $(4, 0)$  is on the graph.

$y$ -intercept:  $(0) - \frac{2}{3}y = 4$   
 $-\frac{2}{3}y = 4$   
 $y = -6$

The point  $(0, -6)$  is on the graph.

b.

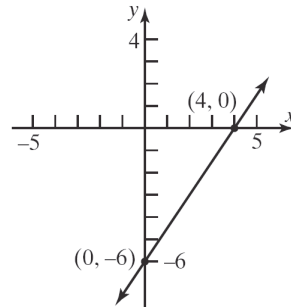



101. a.  $x$ -intercept:  $0.2x - 0.5(0) = 1$   
 $0.2x = 1$   
 $x = 5$

The point  $(5, 0)$  is on the graph.

$y$ -intercept:  $0.2(0) - 0.5y = 1$   
 $-0.5y = 1$   
 $y = -2$

The point  $(0, -2)$  is on the graph.

b.

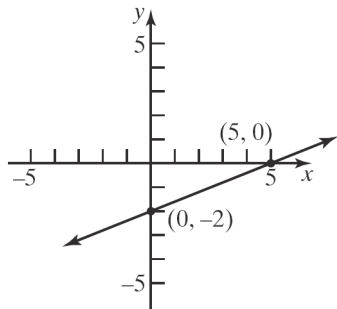

102. a.  $x$ -intercept:  $-0.3x + 0.4(0) = 1.2$   
 $-0.3x = 1.2$   
 $x = -4$

The point  $(-4, 0)$  is on the graph.

$y$ -intercept:  $-0.3(0) + 0.4y = 1.2$   
 $0.4y = 1.2$   
 $y = 3$

The point  $(0, 3)$  is on the graph.

b.

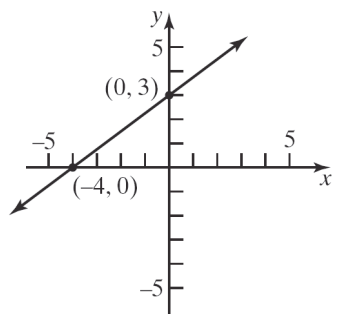

103. The equation of the  $x$ -axis is  $y = 0$ . (The slope is 0 and the  $y$ -intercept is 0.)

104. The equation of the  $y$ -axis is  $x = 0$ . (The slope is undefined.)

105. The slopes are the same but the  $y$ -intercepts are different. Therefore, the two lines are parallel.

106. The slopes are opposite-reciprocals. That is, their product is  $-1$ . Therefore, the lines are perpendicular.

107. The slopes are different and their product does not equal  $-1$ . Therefore, the lines are neither parallel nor perpendicular.

108. The slopes are different and their product does not equal  $-1$  (in fact, the signs are the same so the product is positive). Therefore, the lines are neither parallel nor perpendicular.

109. Intercepts:  $(0, 2)$  and  $(-2, 0)$ . Thus, slope = 1.  
 $y = x + 2$  or  $x - y = -2$

110. Intercepts:  $(0, 1)$  and  $(1, 0)$ . Thus, slope =  $-1$ .  
 $y = -x + 1$  or  $x + y = 1$

111. Intercepts:  $(3, 0)$  and  $(0, 1)$ . Thus, slope =  $-\frac{1}{3}$ .  
 $y = -\frac{1}{3}x + 1$  or  $x + 3y = 3$

112. Intercepts:  $(0, -1)$  and  $(-2, 0)$ . Thus,  
slope =  $-\frac{1}{2}$ .

$$y = -\frac{1}{2}x - 1 \text{ or } x + 2y = -2$$

113.  $P_1 = (-2, 5)$ ,  $P_2 = (1, 3)$ :  $m_1 = \frac{5-3}{-2-1} = \frac{2}{-3} = -\frac{2}{3}$   
 $P_2 = (1, 3)$ ,  $P_3 = (-1, 0)$ :  $m_2 = \frac{3-0}{1-(-1)} = \frac{3}{2}$

Since  $m_1 \cdot m_2 = -1$ , the line segments  $\overline{P_1P_2}$  and  $\overline{P_2P_3}$  are perpendicular. Thus, the points  $P_1$ ,  $P_2$ , and  $P_3$  are vertices of a right triangle.

114.  $P_1 = (1, -1)$ ,  $P_2 = (4, 1)$ ,  $P_3 = (2, 2)$ ,  $P_4 = (5, 4)$

$$m_{12} = \frac{1-(-1)}{4-1} = \frac{2}{3}; \quad m_{24} = \frac{4-1}{5-4} = 3;$$

$$m_{34} = \frac{4-2}{5-2} = \frac{2}{3}; \quad m_{13} = \frac{2-(-1)}{2-1} = 3$$

Each pair of opposite sides are parallel (same slope) and adjacent sides are not perpendicular. Therefore, the vertices are for a parallelogram.

**Chapter 1: Graphs**

115.  $P_1 = (-1, 0)$ ,  $P_2 = (2, 3)$ ,  $P_3 = (1, -2)$ ,  $P_4 = (4, 1)$

$$m_{12} = \frac{3-0}{2-(-1)} = \frac{3}{3} = 1; \quad m_{24} = \frac{1-3}{4-2} = -1;$$

$$m_{34} = \frac{1-(-2)}{4-1} = \frac{3}{3} = 1; \quad m_{13} = \frac{-2-0}{1-(-1)} = -1$$

Opposite sides are parallel (same slope) and adjacent sides are perpendicular (product of slopes is  $-1$ ). Therefore, the vertices are for a rectangle.

116.  $P_1 = (0, 0)$ ,  $P_2 = (1, 3)$ ,  $P_3 = (4, 2)$ ,  $P_4 = (3, -1)$

$$m_{12} = \frac{3-0}{1-0} = 3; \quad m_{23} = \frac{2-3}{4-1} = -\frac{1}{3};$$

$$m_{34} = \frac{-1-2}{3-4} = 3; \quad m_{14} = \frac{-1-0}{3-0} = -\frac{1}{3}$$

$$d_{12} = \sqrt{(1-0)^2 + (3-0)^2} = \sqrt{1+9} = \sqrt{10}$$

$$d_{23} = \sqrt{(4-1)^2 + (2-3)^2} = \sqrt{9+1} = \sqrt{10}$$

$$d_{34} = \sqrt{(3-4)^2 + (-1-2)^2} = \sqrt{1+9} = \sqrt{10}$$

$$d_{14} = \sqrt{(3-0)^2 + (-1-0)^2} = \sqrt{9+1} = \sqrt{10}$$

Opposite sides are parallel (same slope) and adjacent sides are perpendicular (product of slopes is  $-1$ ). In addition, the length of all four sides is the same. Therefore, the vertices are for a square.

117. Let  $x$  = number of miles driven, and let  $C$  = cost in dollars.

Total cost = (cost per mile)(number of miles) + fixed cost

$$C = 0.60x + 39$$

When  $x = 110$ ,  $C = (0.60)(110) + 39 = \$105.00$ .

When  $x = 230$ ,  $C = (0.60)(230) + 39 = \$177.00$ .

118. Let  $x$  = number of pairs of jeans manufactured, and let  $C$  = cost in dollars.

Total cost = (cost per pair)(number of pairs) + fixed cost

$$C = 8x + 500$$

When  $x = 400$ ,  $C = (8)(400) + 500 = \$3700$ .

When  $x = 740$ ,  $C = (8)(740) + 500 = \$6420$ .

119. Let  $x$  = number of miles driven annually, and let  $C$  = cost in dollars.

Total cost = (approx cost per mile)(number of miles) + fixed cost

$$C = 0.16x + 1461$$

120. Let  $x$  = profit in dollars, and let  $S$  = salary in dollars.

Weekly salary = (% share of profit)(profit) + weekly pay

$$S = 0.05x + 375$$

121. a.  $C = 0.0757x + 15.14$ ;  $0 \leq x \leq 800$

b.  $C = 0.0757x + 15.14$   
 $0 \leq x \leq 800$

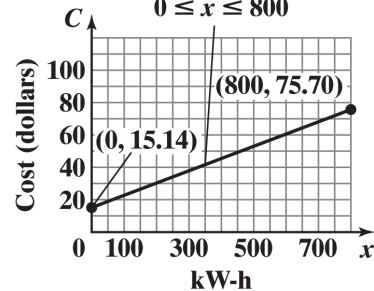

c. For 200 kWh,  
 $C = 0.0757(200) + 15.14 = \$30.28$

d. For 500 kWh,  
 $C = 0.0757(500) + 15.14 = \$52.99$

e. For each usage increase of 1 kWh, the monthly charge increases by \$0.0757 (that is, 7.57 cents).

122. a.  $C = 0.0901x + 7.57$ ;  $0 \leq x \leq 1000$

b.  $C = 0.0901x + 7.57$   
 $0 \leq x \leq 1000$

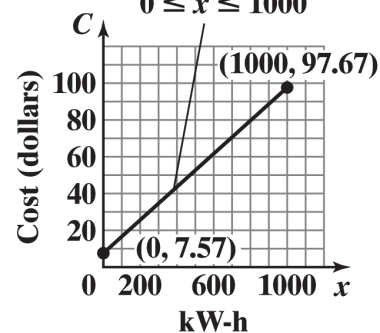

c. For 200 kWh,  
 $C = 0.0901(200) + 7.57 = \$25.59$

d. For 500 kWh,  
 $C = 0.0901(500) + 7.57 = \$52.62$

e. For each usage increase of 1 kWh, the monthly charge increases by \$0.0901 (that is, 9.01 cents).

123.  $(^{\circ}C, ^{\circ}F) = (0, 32); (^{\circ}C, ^{\circ}F) = (100, 212)$

$$\text{slope} = \frac{212 - 32}{100 - 0} = \frac{180}{100} = \frac{9}{5}$$

$$^{\circ}F - 32 = \frac{9}{5}(^{\circ}C - 0)$$

$$^{\circ}F - 32 = \frac{9}{5}(^{\circ}C)$$

$$^{\circ}C = \frac{5}{9}(^{\circ}F - 32)$$

If  $^{\circ}F = 70$ , then

$$^{\circ}C = \frac{5}{9}(70 - 32) = \frac{5}{9}(38)$$

$$^{\circ}C \approx 21.1^{\circ}$$

124. a.  $K = ^{\circ}C + 273$

b.  $^{\circ}C = \frac{5}{9}(^{\circ}F - 32)$

$$K = \frac{5}{9}(^{\circ}F - 32) + 273$$

$$K = \frac{5}{9}^{\circ}F - \frac{160}{9} + 273$$

$$K = \frac{5}{9}^{\circ}F + \frac{2297}{9}$$

$$K = \frac{1}{9}(5^{\circ}F + 2297)$$

125. a. The  $y$ -intercept is  $(0, 30)$ , so  $b = 30$ . Since the ramp drops 2 inches for every 25 inches of run, the slope is  $m = \frac{-2}{25} = -\frac{2}{25}$ . Thus,

$$\text{the equation is } y = -\frac{2}{25}x + 30.$$

b. Let  $y = 0$ .

$$0 = -\frac{2}{25}x + 30$$

$$\frac{2}{25}x = 30$$

$$\frac{25}{2}\left(\frac{2}{25}x\right) = \frac{25}{2}(30)$$

$$x = 375$$

The  $x$ -intercept is  $(375, 0)$ . This means that the ramp meets the floor 375 inches (or 31.25 feet) from the base of the platform.

c. No. From part (b), the run is 31.25 feet which exceeds the required maximum of 30 feet.

d. First, design requirements state that the maximum slope is a drop of 1 inch for each 12 inches of run. This means  $|m| \leq \frac{1}{12}$ .

Second, the run is restricted to be no more than 30 feet = 360 inches. For a rise of 30 inches, this means the minimum slope is

$$\frac{30}{360} = \frac{1}{12}. \text{ That is, } |m| \geq \frac{1}{12}. \text{ Thus, the}$$

only possible slope is  $|m| = \frac{1}{12}$ . The

diagram indicates that the slope is negative. Therefore, the only slope that can be used to obtain the 30-inch rise and still meet design requirements is  $m = -\frac{1}{12}$ . In words, for every 12 inches of run, the ramp must drop *exactly* 1 inch.

126. a. The year 2000 corresponds to  $x = 0$ , and the year 2013 corresponds to  $x = 13$ . Therefore, the points  $(0, 20.6)$  and  $(13, 8.5)$  are on the line. Thus,  $m = \frac{20.6 - 8.5}{0 - 13} = \frac{12.1}{-13} = -0.93$ .

The  $y$ -intercept is 20.6, so  $b = 20.6$  and the equation is  $y = -0.93x + 20.6$

b.  $x$ -intercept:  $0 = -0.93x + 20.6$   
 $x = 22.15$

$$y\text{-intercept: } y = -0.93(0) + 20.6 = 20.6$$

The intercepts are  $(22.15, 0)$  and  $(0, 20.6)$ .

c. The  $y$ -intercept represents the percentage of twelfth graders in 2000 who had reported daily use of cigarettes. The  $x$ -intercept represents the number of years after 2000 when 0% of twelfth graders will have reported daily use of cigarettes.

d. The year 2025 corresponds to  $x = 25$ .  
 $y = -0.93(25) + 20.6 = -2.65$

This prediction is not reasonable since it is negative.

127. a. Let  $x$  = number of boxes to be sold, and  $A$  = money, in dollars, spent on advertising. We have the points  $(x_1, A_1) = (100,000, 40,000)$ ;

**Chapter 1: Graphs**

$$(x_2, A_2) = (200,000, 60,000)$$

$$\text{slope} = \frac{60,000 - 40,000}{200,000 - 100,000}$$

$$= \frac{20,000}{100,000} = \frac{1}{5}$$

$$A - 40,000 = \frac{1}{5}(x - 100,000)$$

$$A - 40,000 = \frac{1}{5}x - 20,000$$

$$A = \frac{1}{5}x + 20,000$$

b. If  $x = 300,000$ , then

$$A = \frac{1}{5}(300,000) + 20,000 = \$80,000$$

c. Each additional box sold requires an additional \$0.20 in advertising.

**128.** Find the slope of the line containing  $(a, b)$  and  $(b, a)$ :

$$\text{slope} = \frac{a - b}{b - a} = -1$$

The slope of the line  $y = x$  is 1.

Since  $-1 \cdot 1 = -1$ , the line containing the points  $(a, b)$  and  $(b, a)$  is perpendicular to the line  $y = x$ .

The midpoint of  $(a, b)$  and  $(b, a)$  is

$$M = \left( \frac{a+b}{2}, \frac{b+a}{2} \right).$$

Since the coordinates are the same, the midpoint lies on the line  $y = x$ .

Note:  $\frac{a+b}{2} = \frac{b+a}{2}$

**129.**  $2x - y = C$

Graph the lines:

$$2x - y = -4$$

$$2x - y = 0$$

$$2x - y = 2$$

All the lines have the same slope, 2. The lines are parallel.

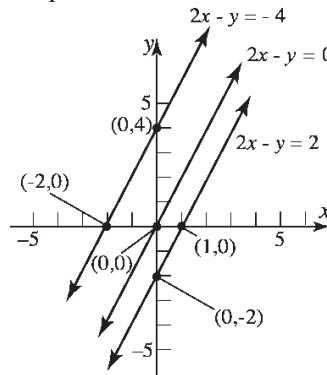

**130.** Refer to Figure 33.

$$\text{length of } \overline{OA} = d(O, A) = \sqrt{1 + m_1^2}$$

$$\text{length of } \overline{OB} = d(O, B) = \sqrt{1 + m_2^2}$$

$$\text{length of } \overline{AB} = d(A, B) = m_1 - m_2$$

Now consider the equation

$$\left( \sqrt{1 + m_1^2} \right)^2 + \left( \sqrt{1 + m_2^2} \right)^2 = (m_1 - m_2)^2$$

If this equation is valid, then  $\triangle AOB$  is a right triangle with right angle at vertex  $O$ .

$$\left( \sqrt{1 + m_1^2} \right)^2 + \left( \sqrt{1 + m_2^2} \right)^2 = (m_1 - m_2)^2$$

$$1 + m_1^2 + 1 + m_2^2 = m_1^2 - 2m_1m_2 + m_2^2$$

$$2 + m_1^2 + m_2^2 = m_1^2 - 2m_1m_2 + m_2^2$$

But we are assuming that  $m_1m_2 = -1$ , so we have

$$2 + m_1^2 + m_2^2 = m_1^2 - 2(-1) + m_2^2$$

$$2 + m_1^2 + m_2^2 = m_1^2 + 2 + m_2^2$$

$$0 = 0$$

Therefore, by the converse of the Pythagorean Theorem,  $\triangle AOB$  is a right triangle with right angle at vertex  $O$ . Thus Line 1 is perpendicular to Line 2.

**131.** (b), (c), (e) and (g)

The line has positive slope and positive  $y$ -intercept.

132. (a), (c), and (g)  
The line has negative slope and positive  $y$ -intercept.
133. (c)  
The equation  $x - y = -2$  has slope 1 and  $y$ -intercept  $(0, 2)$ . The equation  $x - y = 1$  has slope 1 and  $y$ -intercept  $(0, -1)$ . Thus, the lines are parallel with positive slopes. One line has a positive  $y$ -intercept and the other with a negative  $y$ -intercept.
134. (d)  
The equation  $y - 2x = 2$  has slope 2 and  $y$ -intercept  $(0, 2)$ . The equation  $x + 2y = -1$  has slope  $-\frac{1}{2}$  and  $y$ -intercept  $(0, -\frac{1}{2})$ . The lines are perpendicular since  $2(-\frac{1}{2}) = -1$ . One line has a positive  $y$ -intercept and the other with a negative  $y$ -intercept.

135 – 137. Answers will vary.

138. No, the equation of a vertical line cannot be written in slope-intercept form because the slope is undefined.

$$b_1 = b_2 \Rightarrow \frac{b_1}{m} = \frac{b_2}{m} \Rightarrow -\frac{b_1}{m} = -\frac{b_2}{m}$$

$$\text{But } -\frac{b_1}{m} = -\frac{b_2}{m} \Rightarrow \text{Line 1 and Line 2 have the}$$

same  $x$ -intercept, which contradicts the original assumption that the lines have unequal  $x$ -intercepts. Therefore, Line 1 and Line 2 cannot have the same  $y$ -intercept.

139. No, a line does not need to have both an  $x$ -intercept and a  $y$ -intercept. Vertical and horizontal lines have only one intercept (unless they are a coordinate axis). Every line must have at least one intercept.
140. Two lines with equal slopes and equal  $y$ -intercepts are coinciding lines (i.e. the same).
141. Two lines that have the same  $x$ -intercept and  $y$ -intercept (assuming the  $x$ -intercept is not 0) are the same line since a line is uniquely defined by two distinct points.

142. No. Two lines with the same slope and different  $x$ -intercepts are distinct parallel lines and have no points in common.

Assume Line 1 has equation  $y = mx + b_1$  and Line 2 has equation  $y = mx + b_2$ ,

$$\text{Line 1 has } x\text{-intercept } -\frac{b_1}{m} \text{ and } y\text{-intercept } b_1.$$

$$\text{Line 2 has } x\text{-intercept } -\frac{b_2}{m} \text{ and } y\text{-intercept } b_2.$$

Assume also that Line 1 and Line 2 have unequal  $x$ -intercepts.

If the lines have the same  $y$ -intercept, then  $b_1 = b_2$ .

$$-\frac{b}{m_1} = -\frac{b}{m_2}.$$

$$-\frac{b}{m_1} = -\frac{b}{m_2}$$

$$-m_2b = -m_1b$$

$$-m_2b + m_1b = 0$$

$$\text{But } -m_2b + m_1b = 0 \Rightarrow b(m_1 - m_2) = 0 \\ \Rightarrow b = 0$$

$$\text{or } m_1 - m_2 = 0 \Rightarrow m_1 = m_2$$

Since we are assuming that  $m_1 \neq m_2$ , the only way that the two lines can have the same  $x$ -intercept is if  $b = 0$ .

143. Yes. Two distinct lines with the same  $y$ -intercept, but different slopes, can have the same  $x$ -intercept if the  $x$ -intercept is  $x = 0$ .

Assume Line 1 has equation  $y = m_1x + b$  and Line 2 has equation  $y = m_2x + b$ ,

$$\text{Line 1 has } x\text{-intercept } -\frac{b}{m_1} \text{ and } y\text{-intercept } b.$$

$$\text{Line 2 has } x\text{-intercept } -\frac{b}{m_2} \text{ and } y\text{-intercept } b.$$

Assume also that Line 1 and Line 2 have unequal slopes, that is  $m_1 \neq m_2$ .

If the lines have the same  $x$ -intercept, then

144. Answers will vary.

$$145. m = \frac{y_2 - y_1}{x_2 - x_1} = \frac{-4 - 2}{1 - (-3)} = \frac{-6}{4} = -\frac{3}{2}$$

It appears that the student incorrectly found the slope by switching the direction of one of the subtractions.

## Chapter 1: Graphs

The solution set is:  $\{x \mid 1 < x < 4\}$ .

Interval notation:  $(1, 4)$

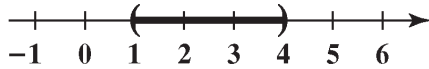

### Section 1.5

1. add;  $(\frac{1}{2} \cdot 10)^2 = 25$

2.  $(x-2)^2 = 9$

$$x-2 = \pm\sqrt{9}$$

$$x-2 = \pm 3$$

$$x = 2 \pm 3$$

$$x = 5 \text{ or } x = -1$$

The solution set is  $\{-1, 5\}$ .

3. False. For example,  $x^2 + y^2 + 2x + 2y + 8 = 0$  is not a circle. It has no real solutions.

4. radius

5. True;  $r^2 = 9 \rightarrow r = 3$

6. False; the center of the circle

$$(x+3)^2 + (y-2)^2 = 13 \text{ is } (-3, 2).$$

7. d

8. a

9. Center =  $(2, 1)$

Radius = distance from  $(0, 1)$  to  $(2, 1)$

$$= \sqrt{(2-0)^2 + (1-1)^2} = \sqrt{4} = 2$$

Equation:  $(x-2)^2 + (y-1)^2 = 4$

10. Center =  $(1, 2)$

Radius = distance from  $(1, 0)$  to  $(1, 2)$

$$= \sqrt{(1-1)^2 + (2-0)^2} = \sqrt{4} = 2$$

Equation:  $(x-1)^2 + (y-2)^2 = 4$

11. Center = midpoint of  $(1, 2)$  and  $(4, 2)$

$$= \left(\frac{1+4}{2}, \frac{2+2}{2}\right) = \left(\frac{5}{2}, 2\right)$$

Radius = distance from  $(\frac{5}{2}, 2)$  to  $(4, 2)$

$$= \sqrt{\left(4 - \frac{5}{2}\right)^2 + (2-2)^2} = \sqrt{\frac{9}{4}} = \frac{3}{2}$$

Equation:  $\left(x - \frac{5}{2}\right)^2 + (y-2)^2 = \frac{9}{4}$

12. Center = midpoint of  $(0, 1)$  and  $(2, 3)$

$$= \left(\frac{0+2}{2}, \frac{1+3}{2}\right) = (1, 2)$$

Radius = distance from  $(1, 2)$  to  $(2, 3)$

$$= \sqrt{(2-1)^2 + (3-2)^2} = \sqrt{2}$$

Equation:  $(x-1)^2 + (y-2)^2 = 2$

13.  $(x-h)^2 + (y-k)^2 = r^2$

$$(x-0)^2 + (y-0)^2 = 2^2$$

$$x^2 + y^2 = 4$$

General form:  $x^2 + y^2 - 4 = 0$

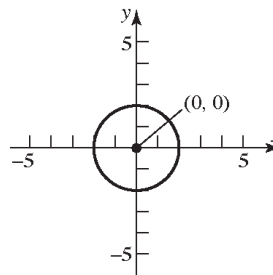

14.  $(x-h)^2 + (y-k)^2 = r^2$

$$(x-0)^2 + (y-0)^2 = 3^2$$

$$x^2 + y^2 = 9$$

General form:  $x^2 + y^2 - 9 = 0$

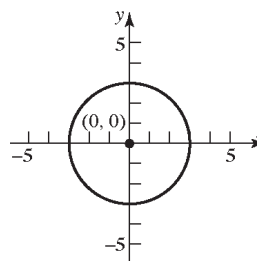

15.  $(x-h)^2 + (y-k)^2 = r^2$

$(x-0)^2 + (y-2)^2 = 2^2$

$x^2 + (y-2)^2 = 4$

General form:  $x^2 + y^2 - 4y + 4 = 4$

$x^2 + y^2 - 4y = 0$

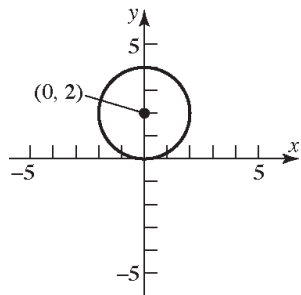

18.  $(x-h)^2 + (y-k)^2 = r^2$

$(x-2)^2 + (y-(-3))^2 = 4^2$

$(x-2)^2 + (y+3)^2 = 16$

General form:  $x^2 - 4x + 4 + y^2 + 6y + 9 = 16$

$x^2 + y^2 - 4x + 6y - 3 = 0$

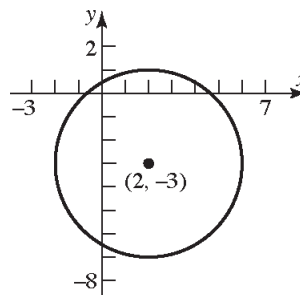

16.  $(x-h)^2 + (y-k)^2 = r^2$

$(x-1)^2 + (y-0)^2 = 3^2$

$(x-1)^2 + y^2 = 9$

General form:  $x^2 - 2x + 1 + y^2 = 9$

$x^2 + y^2 - 2x - 8 = 0$

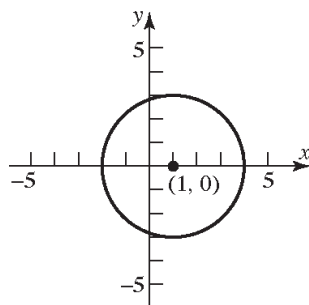

19.  $(x-h)^2 + (y-k)^2 = r^2$

$(x-(-2))^2 + (y-1)^2 = 4^2$

$(x+2)^2 + (y-1)^2 = 16$

General form:  $x^2 + 4x + 4 + y^2 - 2y + 1 = 16$

$x^2 + y^2 + 4x - 2y - 11 = 0$

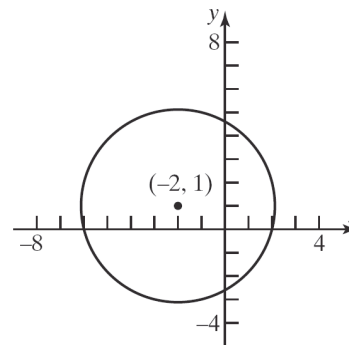

17.  $(x-h)^2 + (y-k)^2 = r^2$

$(x-4)^2 + (y-(-3))^2 = 5^2$

$(x-4)^2 + (y+3)^2 = 25$

General form:

$x^2 - 8x + 16 + y^2 + 6y + 9 = 25$

$x^2 + y^2 - 8x + 6y = 0$

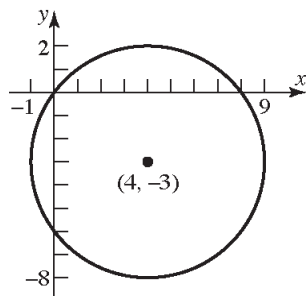

**Chapter 1: Graphs**

20.  $(x-h)^2 + (y-k)^2 = r^2$

$$(x-(-5))^2 + (y-(-2))^2 = 7^2$$

$$(x+5)^2 + (y+2)^2 = 49$$

General form:  $x^2 + 10x + 25 + y^2 + 4y + 4 = 49$

$$x^2 + y^2 + 10x + 4y - 20 = 0$$

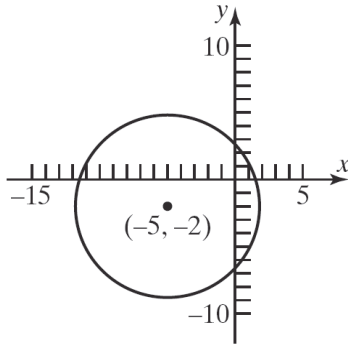

21.  $(x-h)^2 + (y-k)^2 = r^2$

$$\left(x - \frac{1}{2}\right)^2 + (y-0)^2 = \left(\frac{1}{2}\right)^2$$

$$\left(x - \frac{1}{2}\right)^2 + y^2 = \frac{1}{4}$$

General form:  $x^2 - x + \frac{1}{4} + y^2 = \frac{1}{4}$

$$x^2 + y^2 - x = 0$$

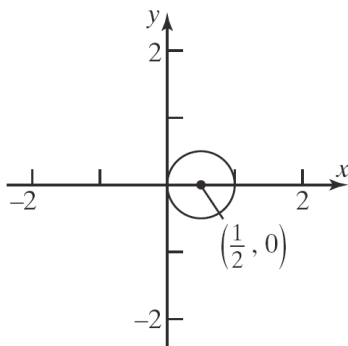

22.  $(x-h)^2 + (y-k)^2 = r^2$

$$(x-0)^2 + \left(y - \left(-\frac{1}{2}\right)\right)^2 = \left(\frac{1}{2}\right)^2$$

$$x^2 + \left(y + \frac{1}{2}\right)^2 = \frac{1}{4}$$

General form:  $x^2 + y^2 + y + \frac{1}{4} = \frac{1}{4}$

$$x^2 + y^2 + y = 0$$

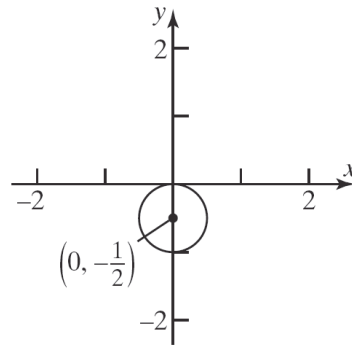

23.  $x^2 + y^2 = 4$

$$x^2 + y^2 = 2^2$$

a. Center: (0,0); Radius = 2

b.

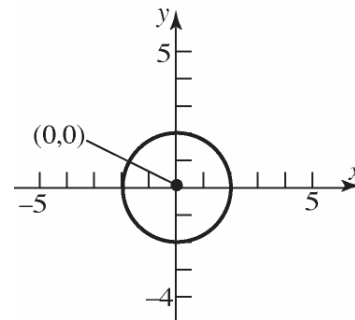

c.  $x$ -intercepts:  $x^2 + (0)^2 = 4$

$$x^2 = 4$$

$$x = \pm\sqrt{4} = \pm 2$$

$y$ -intercepts:  $(0)^2 + y^2 = 4$

$$y^2 = 4$$

$$y = \pm\sqrt{4} = \pm 2$$

The intercepts are  $(-2, 0)$ ,  $(2, 0)$ ,  $(0, -2)$ , and  $(0, 2)$ .



24.  $x^2 + (y-1)^2 = 1$

$$x^2 + (y-1)^2 = 1^2$$

a. Center: (0, 1); Radius = 1

b.

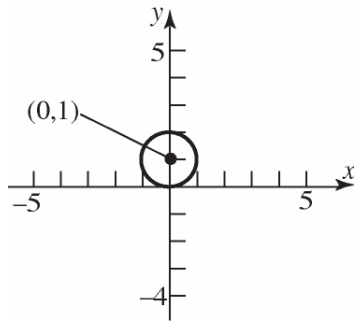

c. x-intercepts:  $x^2 + (0-1)^2 = 1$

$$x^2 + 1 = 1$$

$$x^2 = 0$$

$$x = \pm\sqrt{0} = 0$$

y-intercepts:  $(0)^2 + (y-1)^2 = 1$

$$(y-1)^2 = 1$$

$$y-1 = \pm\sqrt{1}$$

$$y-1 = \pm 1$$

$$y = 1 \pm 1$$

$$y = 2 \text{ or } y = 0$$

The intercepts are (0, 0) and (0, 2).

25.  $2(x-3)^2 + 2y^2 = 8$

$$(x-3)^2 + y^2 = 4$$

a. Center: (3, 0); Radius = 2

b.

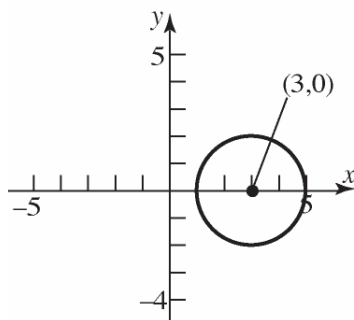

c. x-intercepts:  $(x-3)^2 + (0)^2 = 4$

$$(x-3)^2 = 4$$

$$x-3 = \pm\sqrt{4}$$

$$x-3 = \pm 2$$

$$x = 3 \pm 2$$

$$x = 5 \text{ or } x = 1$$

y-intercepts:  $(0-3)^2 + y^2 = 4$

$$(-3)^2 + y^2 = 4$$

$$9 + y^2 = 4$$

$$y^2 = -5$$

No real solution.

The intercepts are (1, 0) and (5, 0).

26.  $3(x+1)^2 + 3(y-1)^2 = 6$

$$(x+1)^2 + (y-1)^2 = 2$$

a. Center: (-1, 1); Radius =  $\sqrt{2}$

b.

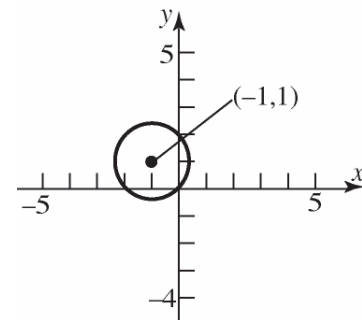

c. x-intercepts:  $(x+1)^2 + (0-1)^2 = 2$

$$(x+1)^2 + (-1)^2 = 2$$

$$(x+1)^2 + 1 = 2$$

$$(x+1)^2 = 1$$

$$x+1 = \pm\sqrt{1}$$

$$x+1 = \pm 1$$

$$x = -1 \pm 1$$

$$x = 0 \text{ or } x = -2$$

**Chapter 1: Graphs**

$$\begin{aligned}
 \text{y-intercepts: } (0+1)^2 + (y-1)^2 &= 2 \\
 (1)^2 + (y-1)^2 &= 2 \\
 1 + (y-1)^2 &= 2 \\
 (y-1)^2 &= 1 \\
 y-1 &= \pm\sqrt{1} \\
 y-1 &= \pm 1 \\
 y &= 1 \pm 1 \\
 y &= 2 \text{ or } y = 0
 \end{aligned}$$

The intercepts are  $(-2, 0)$ ,  $(0, 0)$ , and  $(0, 2)$ .

27.  $x^2 + y^2 - 2x - 4y - 4 = 0$

$$\begin{aligned}
 x^2 - 2x + y^2 - 4y &= 4 \\
 (x^2 - 2x + 1) + (y^2 - 4y + 4) &= 4 + 1 + 4 \\
 (x-1)^2 + (y-2)^2 &= 3^2
 \end{aligned}$$

a. Center:  $(1, 2)$ ; Radius = 3

b.

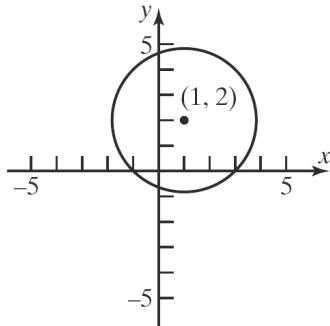

c. x-intercepts:  $(x-1)^2 + (0-2)^2 = 3^2$

$$\begin{aligned}
 (x-1)^2 + (-2)^2 &= 3^2 \\
 (x-1)^2 + 4 &= 9 \\
 (x-1)^2 &= 5 \\
 x-1 &= \pm\sqrt{5} \\
 x &= 1 \pm \sqrt{5}
 \end{aligned}$$

$$\begin{aligned}
 \text{y-intercepts: } (0-1)^2 + (y-2)^2 &= 3^2 \\
 (-1)^2 + (y-2)^2 &= 3^2 \\
 1 + (y-2)^2 &= 9 \\
 (y-2)^2 &= 8 \\
 y-2 &= \pm\sqrt{8} \\
 y-2 &= \pm 2\sqrt{2} \\
 y &= 2 \pm 2\sqrt{2}
 \end{aligned}$$

The intercepts are  $(1-\sqrt{5}, 0)$ ,  $(1+\sqrt{5}, 0)$ ,  $(0, 2-2\sqrt{2})$ , and  $(0, 2+2\sqrt{2})$ .

28.  $x^2 + y^2 + 4x + 2y - 20 = 0$

$$\begin{aligned}
 x^2 + 4x + y^2 + 2y &= 20 \\
 (x^2 + 4x + 4) + (y^2 + 2y + 1) &= 20 + 4 + 1 \\
 (x+2)^2 + (y+1)^2 &= 5^2
 \end{aligned}$$

a. Center:  $(-2, -1)$ ; Radius = 5

b.

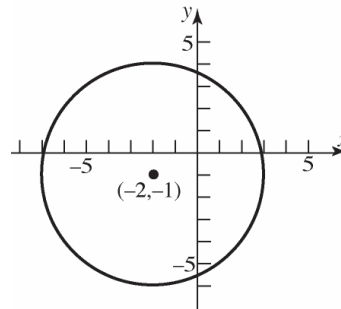

c. x-intercepts:  $(x+2)^2 + (0+1)^2 = 5^2$

$$\begin{aligned}
 (x+2)^2 + 1 &= 25 \\
 (x+2)^2 &= 24 \\
 x+2 &= \pm\sqrt{24} \\
 x+2 &= \pm 2\sqrt{6} \\
 x &= -2 \pm 2\sqrt{6}
 \end{aligned}$$

y-intercepts:  $(0+2)^2 + (y+1)^2 = 5^2$

$$\begin{aligned}
 4 + (y+1)^2 &= 25 \\
 (y+1)^2 &= 21 \\
 y+1 &= \pm\sqrt{21} \\
 y &= -1 \pm \sqrt{21}
 \end{aligned}$$

The intercepts are  $(-2-2\sqrt{6}, 0)$ ,  $(-2+2\sqrt{6}, 0)$ ,  $(0, -1-\sqrt{21})$ , and  $(0, -1+\sqrt{21})$ .

29.  $x^2 + y^2 + 4x - 4y - 1 = 0$   
 $x^2 + 4x + y^2 - 4y = 1$   
 $(x^2 + 4x + 4) + (y^2 - 4y + 4) = 1 + 4 + 4$   
 $(x+2)^2 + (y-2)^2 = 3^2$

a. Center:  $(-2, 2)$ ; Radius = 3

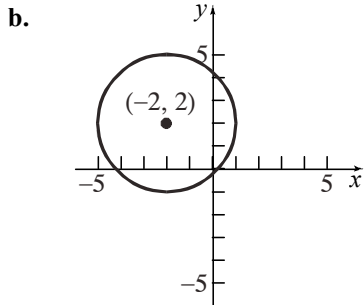

c. x-intercepts:  $(x+2)^2 + (0-2)^2 = 3^2$   
 $(x+2)^2 + 4 = 9$   
 $(x+2)^2 = 5$

$$x+2 = \pm\sqrt{5}$$

$$x = -2 \pm \sqrt{5}$$

y-intercepts:  $(0+2)^2 + (y-2)^2 = 3^2$   
 $4 + (y-2)^2 = 9$   
 $(y-2)^2 = 5$

$$y-2 = \pm\sqrt{5}$$

$$y = 2 \pm \sqrt{5}$$

The intercepts are  $(-2 - \sqrt{5}, 0)$ ,  
 $(-2 + \sqrt{5}, 0)$ ,  $(0, 2 - \sqrt{5})$ , and  $(0, 2 + \sqrt{5})$ .

30.  $x^2 + y^2 - 6x + 2y + 9 = 0$   
 $x^2 - 6x + y^2 + 2y = -9$   
 $(x^2 - 6x + 9) + (y^2 + 2y + 1) = -9 + 9 + 1$   
 $(x-3)^2 + (y+1)^2 = 1^2$

a. Center:  $(3, -1)$ ; Radius = 1

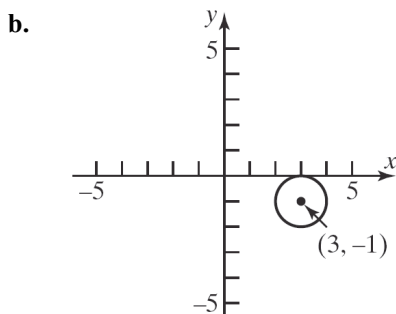

c. x-intercepts:  $(x-3)^2 + (0+1)^2 = 1^2$   
 $(x-3)^2 + 1 = 1$   
 $(x-3)^2 = 0$   
 $x-3 = 0$   
 $x = 3$

y-intercepts:  $(0-3)^2 + (y+1)^2 = 1^2$   
 $9 + (y+1)^2 = 1$   
 $(y+1)^2 = -8$

No real solution.

The intercept only intercept is  $(3, 0)$ .

31.  $x^2 + y^2 - x + 2y + 1 = 0$   
 $x^2 - x + y^2 + 2y = -1$

$$\left(x^2 - x + \frac{1}{4}\right) + (y^2 + 2y + 1) = -1 + \frac{1}{4} + 1$$

$$\left(x - \frac{1}{2}\right)^2 + (y+1)^2 = \left(\frac{1}{2}\right)^2$$

a. Center:  $\left(\frac{1}{2}, -1\right)$ ; Radius =  $\frac{1}{2}$

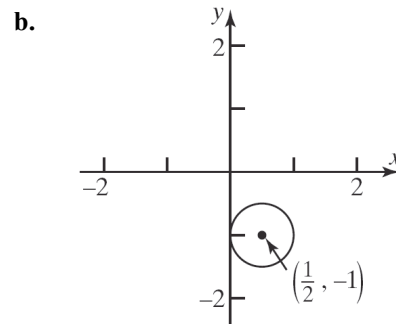

c. x-intercepts:  $\left(x - \frac{1}{2}\right)^2 + (0+1)^2 = \left(\frac{1}{2}\right)^2$   
 $\left(x - \frac{1}{2}\right)^2 + 1 = \frac{1}{4}$   
 $\left(x - \frac{1}{2}\right)^2 = -\frac{3}{4}$

No real solutions

y-intercepts:  $\left(0 - \frac{1}{2}\right)^2 + (y+1)^2 = \left(\frac{1}{2}\right)^2$   
 $\frac{1}{4} + (y+1)^2 = \frac{1}{4}$   
 $(y+1)^2 = 0$   
 $y+1 = 0$   
 $y = -1$

The only intercept is  $(0, -1)$ .

Chapter 1: Graphs

$$32. \quad x^2 + y^2 + x + y - \frac{1}{2} = 0$$

$$x^2 + x + y^2 + y = \frac{1}{2}$$

$$\left(x^2 + x + \frac{1}{4}\right) + \left(y^2 + y + \frac{1}{4}\right) = \frac{1}{2} + \frac{1}{4} + \frac{1}{4}$$

$$\left(x + \frac{1}{2}\right)^2 + \left(y + \frac{1}{2}\right)^2 = 1^2$$

a. Center:  $\left(-\frac{1}{2}, -\frac{1}{2}\right)$ ; Radius = 1

b.

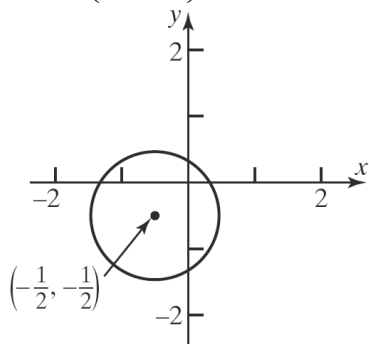

c. x-intercepts:  $\left(x + \frac{1}{2}\right)^2 + \left(0 + \frac{1}{2}\right)^2 = 1^2$

$$\left(x + \frac{1}{2}\right)^2 + \frac{1}{4} = 1$$

$$\left(x + \frac{1}{2}\right)^2 = \frac{3}{4}$$

$$x + \frac{1}{2} = \pm \frac{\sqrt{3}}{2}$$

$$x = \frac{-1 \pm \sqrt{3}}{2}$$

y-intercepts:  $\left(0 + \frac{1}{2}\right)^2 + \left(y + \frac{1}{2}\right)^2 = 1^2$

$$\frac{1}{4} + \left(y + \frac{1}{2}\right)^2 = 1$$

$$\left(y + \frac{1}{2}\right)^2 = \frac{3}{4}$$

$$y + \frac{1}{2} = \pm \frac{\sqrt{3}}{2}$$

$$y = \frac{-1 \pm \sqrt{3}}{2}$$

The intercepts are  $\left(\frac{-1-\sqrt{3}}{2}, 0\right)$ ,  $\left(\frac{-1+\sqrt{3}}{2}, 0\right)$ ,  
 $\left(0, \frac{-1-\sqrt{3}}{2}\right)$ , and  $\left(0, \frac{-1+\sqrt{3}}{2}\right)$ .

$$33. \quad 2x^2 + 2y^2 - 12x + 8y - 24 = 0$$

$$x^2 + y^2 - 6x + 4y = 12$$

$$x^2 - 6x + y^2 + 4y = 12$$

$$(x^2 - 6x + 9) + (y^2 + 4y + 4) = 12 + 9 + 4$$

$$(x - 3)^2 + (y + 2)^2 = 5^2$$

a. Center: (3, -2); Radius = 5

b.

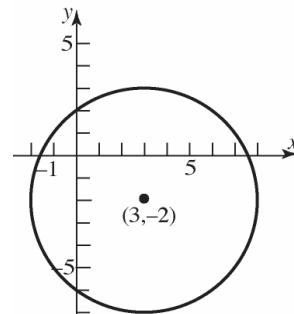

c. x-intercepts:  $(x - 3)^2 + (0 + 2)^2 = 5^2$

$$(x - 3)^2 + 4 = 25$$

$$(x - 3)^2 = 21$$

$$x - 3 = \pm\sqrt{21}$$

$$x = 3 \pm \sqrt{21}$$

y-intercepts:  $(0 - 3)^2 + (y + 2)^2 = 5^2$

$$9 + (y + 2)^2 = 25$$

$$(y + 2)^2 = 16$$

$$y + 2 = \pm 4$$

$$y = -2 \pm 4$$

$$y = 2 \quad \text{or} \quad y = -6$$

The intercepts are  $(3 - \sqrt{21}, 0)$ ,  $(3 + \sqrt{21}, 0)$ ,  
 $(0, -6)$ , and  $(0, 2)$ .

34. a.  $2x^2 + 2y^2 + 8x + 7 = 0$

$$2x^2 + 8x + 2y^2 = -7$$

$$x^2 + 4x + y^2 = -\frac{7}{2}$$

$$(x^2 + 4x + 4) + y^2 = -\frac{7}{2} + 4$$

$$(x + 2)^2 + y^2 = \frac{1}{2}$$

$$(x + 2)^2 + y^2 = \left(\frac{\sqrt{2}}{2}\right)^2$$

Center: (-2, 0); Radius =  $\frac{\sqrt{2}}{2}$

b.

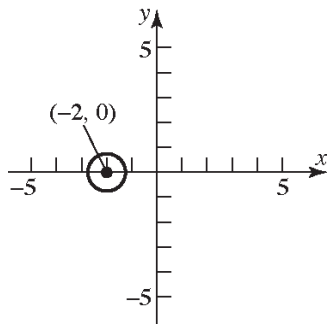

c. x-intercepts:  $(x+2)^2 + (0)^2 = \frac{1}{2}$   
 $(x+2)^2 = \frac{1}{2}$

$$x+2 = \pm\sqrt{\frac{1}{2}}$$

$$x+2 = \pm\frac{\sqrt{2}}{2}$$

$$x = -2 \pm \frac{\sqrt{2}}{2}$$

y-intercepts:  $(0+2)^2 + y^2 = \frac{1}{2}$

$$4 + y^2 = \frac{1}{2}$$

$$y^2 = -\frac{7}{2}$$

No real solutions.

The intercepts are  $\left(-2 - \frac{\sqrt{2}}{2}, 0\right)$  and

$$\left(-2 + \frac{\sqrt{2}}{2}, 0\right).$$

35.  $2x^2 + 8x + 2y^2 = 0$

$$x^2 + 4x + y^2 = 0$$

$$x^2 + 4x + 4 + y^2 = 0 + 4$$

$$(x+2)^2 + y^2 = 2^2$$

a. Center:  $(-2, 0)$ ; Radius:  $r = 2$

b.

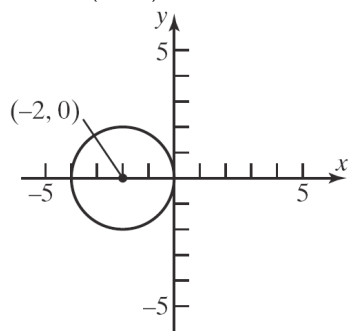

c. x-intercepts:  $(x+2)^2 + (0)^2 = 2^2$

$$(x+2)^2 = 4$$

$$(x+2)^2 = \pm\sqrt{4}$$

$$x+2 = \pm 2$$

$$x = -2 \pm 2$$

$$x = 0 \text{ or } x = -4$$

y-intercepts:  $(0+2)^2 + y^2 = 2^2$

$$4 + y^2 = 4$$

$$y^2 = 0$$

$$y = 0$$

The intercepts are  $(-4, 0)$  and  $(0, 0)$ .

36.  $3x^2 + 3y^2 - 12y = 0$

$$x^2 + y^2 - 4y = 0$$

$$x^2 + y^2 - 4y + 4 = 0 + 4$$

$$x^2 + (y-2)^2 = 4$$

a. Center:  $(0, 2)$ ; Radius:  $r = 2$

b.

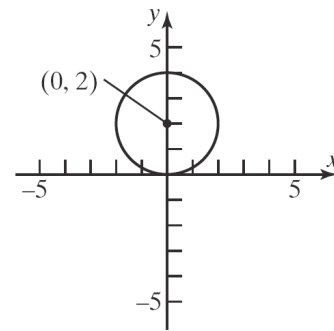

c. x-intercepts:  $x^2 + (0-2)^2 = 4$

$$x^2 + 4 = 4$$

$$x^2 = 0$$

$$x = 0$$

y-intercepts:  $0^2 + (y-2)^2 = 4$

$$(y-2)^2 = 4$$

$$y-2 = \pm\sqrt{4}$$

$$y-2 = \pm 2$$

$$y = 2 \pm 2$$

$$y = 4 \text{ or } y = 0$$

The intercepts are  $(0, 0)$  and  $(0, 4)$ .

**Chapter 1: Graphs**

37. Center at (0, 0); containing point (-2, 3).

$$r = \sqrt{(-2-0)^2 + (3-0)^2} = \sqrt{4+9} = \sqrt{13}$$

$$\begin{aligned} \text{Equation: } (x-0)^2 + (y-0)^2 &= (\sqrt{13})^2 \\ x^2 + y^2 &= 13 \end{aligned}$$

38. Center at (1, 0); containing point (-3, 2).

$$r = \sqrt{(-3-1)^2 + (2-0)^2} = \sqrt{16+4} = \sqrt{20} = 2\sqrt{5}$$

$$\begin{aligned} \text{Equation: } (x-1)^2 + (y-0)^2 &= (\sqrt{20})^2 \\ (x-1)^2 + y^2 &= 20 \end{aligned}$$

39. Center at (2, 3); tangent to the  $x$ -axis.

$$r = 3$$

$$\begin{aligned} \text{Equation: } (x-2)^2 + (y-3)^2 &= 3^2 \\ (x-2)^2 + (y-3)^2 &= 9 \end{aligned}$$

40. Center at (-3, 1); tangent to the  $y$ -axis.

$$r = 3$$

$$\begin{aligned} \text{Equation: } (x+3)^2 + (y-1)^2 &= 3^2 \\ (x+3)^2 + (y-1)^2 &= 9 \end{aligned}$$

41. Endpoints of a diameter are (1, 4) and (-3, 2).  
The center is at the midpoint of that diameter:

$$\text{Center: } \left( \frac{1+(-3)}{2}, \frac{4+2}{2} \right) = (-1, 3)$$

$$\text{Radius: } r = \sqrt{(1-(-1))^2 + (4-3)^2} = \sqrt{4+1} = \sqrt{5}$$

$$\begin{aligned} \text{Equation: } (x-(-1))^2 + (y-3)^2 &= (\sqrt{5})^2 \\ (x+1)^2 + (y-3)^2 &= 5 \end{aligned}$$

42. Endpoints of a diameter are (4, 3) and (0, 1).  
The center is at the midpoint of that diameter:

$$\text{Center: } \left( \frac{4+0}{2}, \frac{3+1}{2} \right) = (2, 2)$$

$$\text{Radius: } r = \sqrt{(4-2)^2 + (3-2)^2} = \sqrt{4+1} = \sqrt{5}$$

$$\begin{aligned} \text{Equation: } (x-2)^2 + (y-2)^2 &= (\sqrt{5})^2 \\ (x-2)^2 + (y-2)^2 &= 5 \end{aligned}$$

43. Center at (-1, 3); tangent to the line  $y = 2$ .

This means that the circle contains the point (-1, 2), so the radius is  $r = 1$ .

$$\begin{aligned} \text{Equation: } (x+1)^2 + (y-3)^2 &= (1)^2 \\ (x+1)^2 + (y-3)^2 &= 1 \end{aligned}$$

44. Center at (4, -2); tangent to the line  $x = 1$ .

This means that the circle contains the point (1, -2), so the radius is  $r = 3$ .

$$\begin{aligned} \text{Equation: } (x-4)^2 + (y+2)^2 &= (3)^2 \\ (x-4)^2 + (y+2)^2 &= 9 \end{aligned}$$

45. (c); Center: (1, -2); Radius = 2

46. (d); Center: (-3, 3); Radius = 3

47. (b); Center: (-1, 2); Radius = 2

48. (a); Center: (-3, 3); Radius = 3

49. Let the upper-right corner of the square be the point  $(x, y)$ . The circle and the square are both centered about the origin. Because of symmetry, we have that  $x = y$  at the upper-right corner of the square. Therefore, we get

$$x^2 + y^2 = 9$$

$$x^2 + x^2 = 9$$

$$2x^2 = 9$$

$$x^2 = \frac{9}{2}$$

$$x = \sqrt{\frac{9}{2}} = \frac{3\sqrt{2}}{2}$$

The length of one side of the square is  $2x$ . Thus, the area is

$$A = s^2 = \left( 2 \cdot \frac{3\sqrt{2}}{2} \right)^2 = (3\sqrt{2})^2 = 18 \text{ square units.}$$

50. The area of the shaded region is the area of the circle, less the area of the square. Let the upper-right corner of the square be the point  $(x, y)$ .

The circle and the square are both centered about the origin. Because of symmetry, we have that  $x = y$  at the upper-right corner of the square.

Therefore, we get

$$x^2 + y^2 = 36$$

$$x^2 + x^2 = 36$$

$$2x^2 = 36$$

$$x^2 = 18$$

$$x = 3\sqrt{2}$$

The length of one side of the square is  $2x$ . Thus,

the area of the square is  $(2 \cdot 3\sqrt{2})^2 = 72$  square

units. From the equation of the circle, we have

$r = 6$ . The area of the circle is

$$\pi r^2 = \pi(6)^2 = 36\pi \text{ square units.}$$

Therefore, the area of the shaded region is

$$A = 36\pi - 72 \text{ square units.}$$

51. The diameter of the Ferris wheel was 250 feet, so the radius was 125 feet. The maximum height was 264 feet, so the center was at a height of  $264 - 125 = 139$  feet above the ground. Since the center of the wheel is on the  $y$ -axis, it is the point  $(0, 139)$ . Thus, an equation for the wheel is:

$$(x-0)^2 + (y-139)^2 = 125^2$$

$$x^2 + (y-139)^2 = 15,625$$

52. The diameter of the wheel is 520 feet, so the radius is 260 feet. The maximum height is 550 feet, so the center of the wheel is at a height of  $550 - 260 = 290$  feet above the ground. Since the center of the wheel is on the  $y$ -axis, it is the point  $(0, 290)$ . Thus, an equation for the wheel is:

$$(x-0)^2 + (y-290)^2 = 260^2$$

$$x^2 + (y-290)^2 = 67,600$$

53.  $x^2 + y^2 + 2x + 4y - 4091 = 0$

$$x^2 + 2x + y^2 + 4y - 4091 = 0$$

$$x^2 + 2x + 1 + y^2 + 4y + 4 = 4091 + 5$$

$$(x+1)^2 + (y+2)^2 = 4096$$

The circle representing Earth has center  $(-1, -2)$

and radius  $= \sqrt{4096} = 64$ .

So the radius of the satellite's orbit is

$$64 + 0.6 = 64.6 \text{ units.}$$

The equation of the orbit is

$$(x+1)^2 + (y+2)^2 = (64.6)^2$$

$$x^2 + y^2 + 2x + 4y - 4168.16 = 0$$

54. a.  $x^2 + (mx+b)^2 = r^2$

$$x^2 + m^2x^2 + 2bmx + b^2 = r^2$$

$$(1+m^2)x^2 + 2bmx + b^2 - r^2 = 0$$

There is one solution if and only if the discriminant is zero.

$$(2bm)^2 - 4(1+m^2)(b^2 - r^2) = 0$$

$$4b^2m^2 - 4b^2 + 4r^2 - 4b^2m^2 + 4m^2r^2 = 0$$

$$-4b^2 + 4r^2 + 4m^2r^2 = 0$$

$$-b^2 + r^2 + m^2r^2 = 0$$

$$r^2(1+m^2) = b^2$$

- b. Using the quadratic formula, the result from part (a), and knowing that the discriminant is zero, we get:

$$(1+m^2)x^2 + 2bmx + b^2 - r^2 = 0$$

$$x = \frac{-2bm}{2(1+m^2)} = \frac{-bm}{(1+m^2)} = \frac{-bmr^2}{r^2(1+m^2)} = \frac{-mr^2}{r^2(1+m^2)}$$

$$y = m\left(\frac{-mr^2}{r^2(1+m^2)}\right) + b$$

$$= \frac{-m^2r^2}{r^2(1+m^2)} + b = \frac{-m^2r^2 + b^2}{r^2(1+m^2)} = \frac{r^2}{r^2(1+m^2)}$$

- c. The slope of the tangent line is  $m$ . The slope of the line joining the point of tangency and the center is:

$$\frac{\left(\frac{r^2}{b} - 0\right)}{\left(\frac{-mr^2}{b} - 0\right)} = \frac{r^2}{b} \cdot \frac{b}{-mr^2} = -\frac{1}{m}$$

Therefore, the tangent line is perpendicular to the line containing the center of the circle and the point of tangency.

55.  $x^2 + y^2 = 9$

Center:  $(0, 0)$

Slope from center to  $(1, 2\sqrt{2})$  is

$$\frac{2\sqrt{2} - 0}{1 - 0} = \frac{2\sqrt{2}}{1} = 2\sqrt{2}$$

Slope of the tangent line is  $-\frac{1}{2\sqrt{2}} = -\frac{\sqrt{2}}{4}$ .

**Chapter 1: Graphs**

Equation of the tangent line is:

$$y - 2\sqrt{2} = -\frac{\sqrt{2}}{4}(x-1)$$

$$y - 2\sqrt{2} = -\frac{\sqrt{2}}{4}x + \frac{\sqrt{2}}{4}$$

$$4y - 8\sqrt{2} = -\sqrt{2}x + \sqrt{2}$$

$$\sqrt{2}x + 4y = 9\sqrt{2}$$

$$\sqrt{2}x + 4y - 9\sqrt{2} = 0$$

56.  $x^2 + y^2 - 4x + 6y + 4 = 0$

$$(x^2 - 4x + 4) + (y^2 + 6y + 9) = -4 + 4 + 9$$

$$(x-2)^2 + (y+3)^2 = 9$$

Center: (2, -3)

Slope from center to  $(3, 2\sqrt{2} - 3)$  is

$$\frac{2\sqrt{2} - 3 - (-3)}{3 - 2} = \frac{2\sqrt{2}}{1} = 2\sqrt{2}$$

Slope of the tangent line is:  $\frac{-1}{2\sqrt{2}} = -\frac{\sqrt{2}}{4}$

Equation of the tangent line:

$$y - (2\sqrt{2} - 3) = -\frac{\sqrt{2}}{4}(x - 3)$$

$$y - 2\sqrt{2} + 3 = -\frac{\sqrt{2}}{4}x + \frac{3\sqrt{2}}{4}$$

$$4y - 8\sqrt{2} + 12 = -\sqrt{2}x + 3\sqrt{2}$$

$$\sqrt{2}x + 4y - 11\sqrt{2} + 12 = 0$$

57. Let  $(h, k)$  be the center of the circle.

$$x - 2y + 4 = 0$$

$$2y = x + 4$$

$$y = \frac{1}{2}x + 2$$

The slope of the tangent line is  $\frac{1}{2}$ . The slope

from  $(h, k)$  to  $(0, 2)$  is  $-2$ .

$$\frac{2 - k}{0 - h} = -2$$

$$2 - k = 2h$$

The other tangent line is  $y = 2x - 7$ , and it has

slope 2. The slope from  $(h, k)$  to  $(3, -1)$  is

$$-\frac{1}{2}$$

$$\frac{-1 - k}{3 - h} = -\frac{1}{2}$$

$$2 + 2k = 3 - h$$

$$2k = 1 - h$$

$$h = 1 - 2k$$

Solve the two equations in  $h$  and  $k$ :

$$2 - k = 2(1 - 2k)$$

$$2 - k = 2 - 4k$$

$$3k = 0$$

$$k = 0$$

$$h = 1 - 2(0) = 1$$

The center of the circle is  $(1, 0)$ .

58. Find the centers of the two circles:

$$x^2 + y^2 - 4x + 6y + 4 = 0$$

$$(x^2 - 4x + 4) + (y^2 + 6y + 9) = -4 + 4 + 9$$

$$(x-2)^2 + (y+3)^2 = 9$$

Center:  $(2, -3)$

$$x^2 + y^2 + 6x + 4y + 9 = 0$$

$$(x^2 + 6x + 9) + (y^2 + 4y + 4) = -9 + 9 + 4$$

$$(x+3)^2 + (y+2)^2 = 4$$

Center:  $(-3, -2)$

Find the slope of the line containing the centers:

$$m = \frac{-2 - (-3)}{-3 - 2} = -\frac{1}{5}$$

Find the equation of the line containing the centers:

$$y + 3 = -\frac{1}{5}(x - 2)$$

$$5y + 15 = -x + 2$$

$$x + 5y = -13$$

$$x + 5y + 13 = 0$$



59. Consider the following diagram:

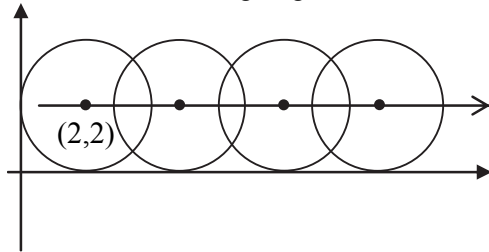

Therefore, the path of the center of the circle has the equation  $y = 2$ .

60.  $C = 2\pi r$

$$6\pi = 2\pi r$$

$$\frac{6\pi}{2\pi} = \frac{2\pi r}{2\pi}$$

$$3 = r$$

The radius is 3 units long.

61. (b), (c), (e) and (g)

We need  $h, k > 0$  and  $(0, 0)$  on the graph.

62. (b), (e) and (g)

We need  $h < 0$ ,  $k = 0$ , and  $|h| > r$ .

63. Answers will vary.

64. The student has the correct radius, but the signs of the coordinates of the center are incorrect. The student needs to write the equation in the standard form  $(x-h)^2 + (y-k)^2 = r^2$ .

$$(x+3)^2 + (y-2)^2 = 16$$

$$(x-(-3))^2 + (y-2)^2 = 4^2$$

Thus,  $(h, k) = (-3, 2)$  and  $r = 4$ .

## Chapter 1 Review

1.  $(0, 0), (4, 2)$

a. distance =  $\sqrt{(4-0)^2 + (2-0)^2}$   
 $= \sqrt{16+4} = \sqrt{20}$   
 $= 2\sqrt{5}$

b. midpoint =  $\left(\frac{0+4}{2}, \frac{0+2}{2}\right) = \left(\frac{4}{2}, \frac{2}{2}\right) = (2, 1)$

c. slope =  $\frac{\Delta y}{\Delta x} = \frac{2-0}{4-0} = \frac{2}{4} = \frac{1}{2}$

d. When  $x$  increases by 2 units,  $y$  increases by 1 unit.

2.  $(1, -1), (-2, 3)$

a. distance =  $\sqrt{(-2-1)^2 + (3-(-1))^2}$   
 $= \sqrt{9+16} = \sqrt{25} = 5$

b. midpoint =  $\left(\frac{1+(-2)}{2}, \frac{-1+3}{2}\right)$   
 $= \left(\frac{-1}{2}, \frac{2}{2}\right) = \left(-\frac{1}{2}, 1\right)$

c. slope =  $\frac{\Delta y}{\Delta x} = \frac{3-(-1)}{-2-1} = \frac{4}{-3} = -\frac{4}{3}$

d. When  $x$  increases by 3 units,  $y$  decreases by 4 units.

3.  $(4, -4), (4, 8)$

a. distance =  $\sqrt{(4-4)^2 + (8-(-4))^2}$   
 $= \sqrt{0+144} = \sqrt{144} = 12$

b. midpoint =  $\left(\frac{4+4}{2}, \frac{-4+8}{2}\right)$   
 $= \left(\frac{8}{2}, \frac{4}{2}\right) = (4, 2)$

c. slope =  $\frac{\Delta y}{\Delta x} = \frac{8-(-4)}{4-4} = \frac{12}{0}$ , undefined

d. Undefined slope means the points lie on a vertical line, in this case  $x = 4$ .

4.  $(-2, -1), (3, -1)$

a. distance =  $\sqrt{(3-(-2))^2 + (-1-(-1))^2}$   
 $= \sqrt{25+0} = \sqrt{25} = 5$

b. midpoint =  $\left(\frac{-2+3}{2}, \frac{-1+(-1)}{2}\right)$   
 $= \left(\frac{1}{2}, -\frac{2}{2}\right) = \left(\frac{1}{2}, -1\right)$

**Chapter 1: Graphs**

c.  $\text{slope} = \frac{\Delta y}{\Delta x} = \frac{-1 - (-1)}{3 - (-2)} = \frac{0}{5} = 0$

d. Slope = 0 means the points lie on a horizontal line, in this case  $y = -1$ .

5.  $(-4, 0), (0, 0), (2, 0), (0, -2), (0, 0), (0, 2)$

6.  $y = -x^2 + 15$

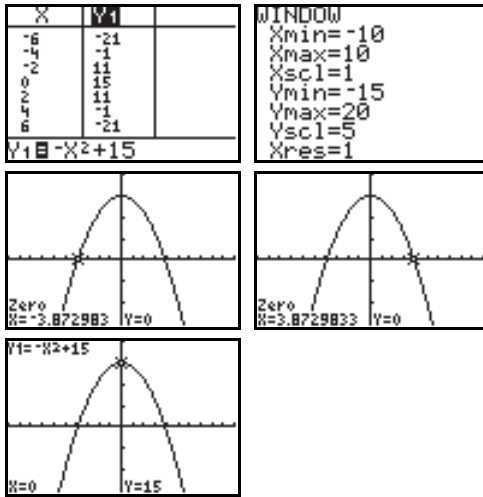

The intercepts are  $(0, 15)$ ,  $(-3.87, 0)$ , and  $(3.87, 0)$ .

7.  $2x - 3y = 6$   
 $-3y = -2x + 6$   
 $y = \frac{2}{3}x - 2$

x-intercepts:	y-intercept:
$2x - 3(0) = 6$	$2(0) - 3y = 6$
$2x = 6$	$-3y = 6$
$x = 3$	$y = -2$

The intercepts are  $(3, 0)$  and  $(0, -2)$ .

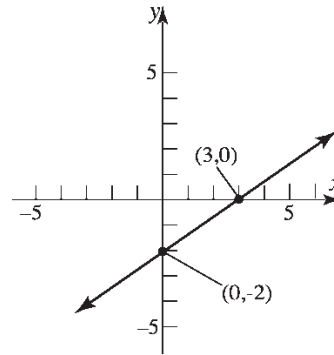

8.  $y = x^2 - 9$   
x-intercepts:  $0 = x^2 - 9$   
 $0 = (x - 3)(x + 3)$   
 $x = 3$  or  $x = -3$   
y-intercept:  $y = 0^2 - 9$   
 $y = -9$

The intercepts are  $(-3, 0)$ ,  $(3, 0)$ , and  $(0, -9)$ .

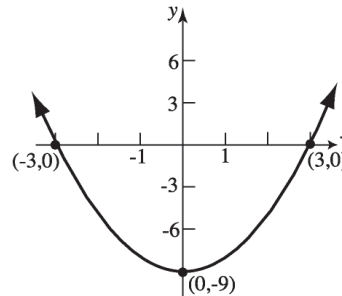

9.  $x^2 + 2y = 16$   
 $2y = -x^2 + 16$   
 $y = -\frac{1}{2}x^2 + 8$

x-intercepts:	y-intercept:
$x^2 + 2(0) = 16$	$0^2 + 2y = 16$
$x^2 = 16$	$2y = 16$
$x = \pm 4$	$y = 8$

The intercepts are  $(-4, 0)$ ,  $(4, 0)$ , and  $(0, 8)$ .

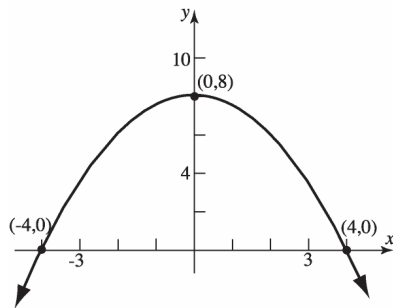

10.  $2x = 3y^2$

x-axis:  $2x = 3(-y)^2$   
 $2x = 3y^2$  same

y-axis:  $2(-x) = 3y^2$   
 $-2x = 3y^2$  different

origin:  $2(-x) = 3(-y)^2$   
 $-2x = 3y^2$  different

Therefore, the graph of the equation has x-axis symmetry.

11.  $x^2 + 4y^2 = 16$

x-axis:  $x^2 + 4(-y)^2 = 16$   
 $x^2 + 4y^2 = 16$  same

y-axis:  $(-x)^2 + 4y^2 = 16$   
 $x^2 + 4y^2 = 16$  same

origin:  $(-x)^2 + 4(-y)^2 = 16$   
 $x^2 + 4y^2 = 16$  same

Therefore, the graph of the equation has x-axis, y-axis, and origin symmetry.

12.  $y = x^4 - 3x^2 - 4$

x-intercepts:	y-intercepts:
$0 = x^4 - 3x^2 - 4$	$y = (0)^4 - 3(0)^2 - 4$
$0 = (x^2 - 4)(x^2 + 1)$	$= -4$
$x^2 - 4 = 0$	
$x^2 = 4$	
$x = \pm 2$	

The intercepts are  $(-2, 0)$ ,  $(2, 0)$ ,  $(0, -4)$ , and  $(0, 2)$ .

Test x-axis symmetry: Let  $y = -y$

$$-y = x^4 - 3x^2 - 4$$

$$y = -x^4 + 3x^2 + 4 \quad \text{different}$$

Test y-axis symmetry: Let  $x = -x$

$$y = (-x)^4 - 3(-x)^2 - 4$$

$$y = x^4 - 3x^2 - 4 \quad \text{same}$$

Test origin symmetry: Let  $x = -x$  and  $y = -y$ .

$$-y = (-x)^4 - 3(-x)^2 - 4$$

$$-y = x^4 - 3x^2 - 4$$

$$y = -x^4 + 3x^2 + 4 \quad \text{different}$$

Therefore, the graph will have y-axis symmetry.

13.  $y = x^3 - x$

x-axis:  $(-y) = x^3 - x$   
 $-y = x^3 - x$  different

y-axis:  $y = (-x)^3 - (-x)$   
 $y = -x^3 + x$  different

origin:  $(-y) = (-x)^3 - (-x)$   
 $-y = -x^3 + x$   
 $y = x^3 - x$  same

Therefore, the equation of the graph has origin symmetry.

14.  $x^2 + x + y^2 + 2y = 0$

x-axis:  $x^2 + x + (-y)^2 + 2(-y) = 0$   
 $x^2 + x + y^2 - 2y = 0$  different

y-axis:  $(-x)^2 + (-x) + y^2 + 2y = 0$   
 $x^2 - x + y^2 + 2y = 0$  different

origin:  
 $(-x)^2 + (-x) + (-y)^2 + 2(-y) = 0$   
 $x^2 - x + y^2 - 2y = 0$  different

Therefore, the graph of the equation has none of the three symmetries.

Chapter 1: Graphs

15.

$x$	$y = x^3$	$(x, y)$
-2	$y = (-2)^3 = -8$	$(-2, -8)$
0	$y = (0)^3 = 0$	$(0, 0)$
2	$y = (2)^3 = 8$	$(2, 8)$

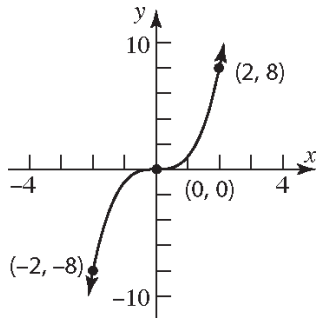

16.  $x^3 - 5x + 3 = 0$   
Use the Zero option from the CALC menu.

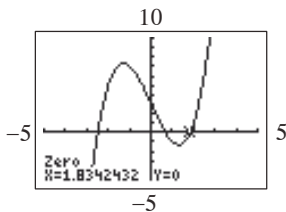
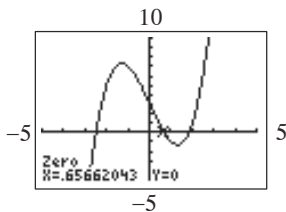
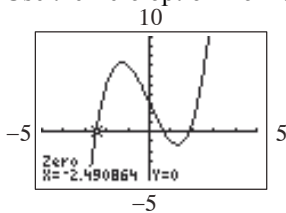

The solution set is  $\{-2.49, 0.66, 1.83\}$ .

17.  $x^4 - 3 = 2x + 1$   
Use the Intersect option on the CALC menu.

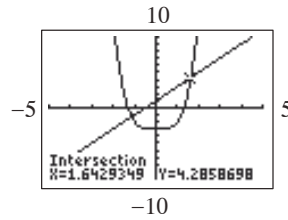
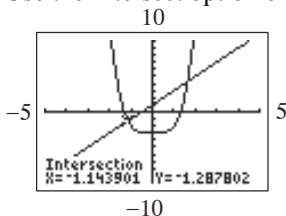

The solution set is  $\{-1.14, 1.64\}$ .

18. Slope = -2; containing  $(3, -1)$

$$y - y_1 = m(x - x_1)$$

$$y - (-1) = -2(x - 3)$$

$$y + 1 = -2x + 6$$

$$y = -2x + 5$$

$$2x + y = 5 \text{ or } y = -2x + 5$$

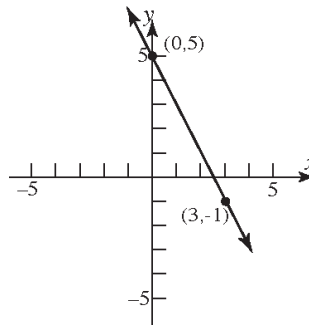

19. Slope = 0; containing the point  $(-5, 4)$

$$y - y_1 = m(x - x_1)$$

$$y - 4 = 0(x - (-5))$$

$$y - 4 = 0$$

$$y = 4$$

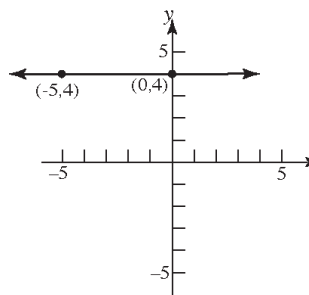

20. Slope undefined; containing  $(-3, 4)$ .  
 This is a vertical line.  
 $x = -3$   
 No slope-intercept form.

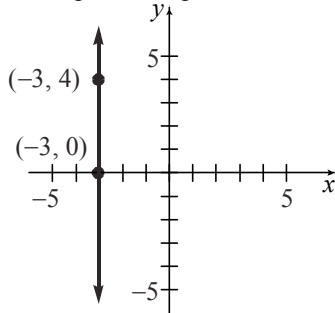

21. x-intercept = 2 or the point  $(2, 0)$ ;  
 Containing the point  $(4, -5)$

$$m = \frac{-5 - 0}{4 - 2} = \frac{-5}{2} = -\frac{5}{2}$$

$$y - y_1 = m(x - x_1)$$

$$y - 0 = -\frac{5}{2}(x - 2)$$

$$y = -\frac{5}{2}x + 5$$

$$5x + 2y = 10 \text{ or } y = -\frac{5}{2}x + 5$$

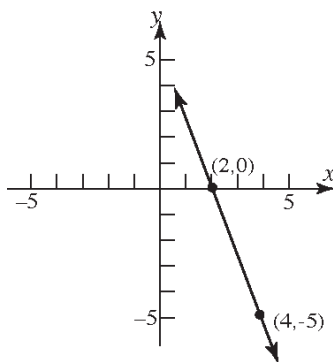

22. y-intercept =  $-2$ ; containing  $(5, -3)$   
 Points are  $(5, -3)$  and  $(0, -2)$

$$m = \frac{-2 - (-3)}{0 - 5} = \frac{1}{-5} = -\frac{1}{5}$$

$$y = mx + b$$

$$y = -\frac{1}{5}x - 2$$

$$x + 5y = -10 \text{ or } y = -\frac{1}{5}x - 2$$

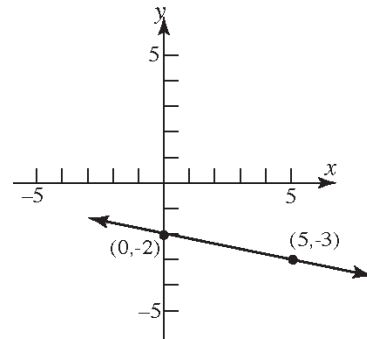

23. Containing the points  $(3, -4)$  and  $(2, 1)$

$$m = \frac{1 - (-4)}{2 - 3} = \frac{5}{-1} = -5$$

$$y - y_1 = m(x - x_1)$$

$$y - (-4) = -5(x - 3)$$

$$y + 4 = -5x + 15$$

$$y = -5x + 11$$

$$5x + y = 11 \text{ or } y = -5x + 11$$

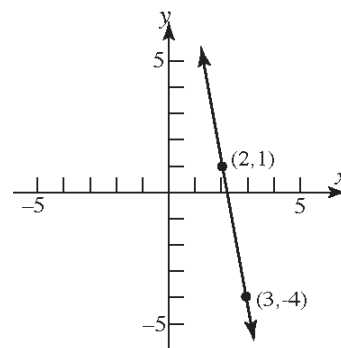

**Chapter 1: Graphs**

24. Parallel to  $2x - 3y = -4$ ;

Slope =  $\frac{2}{3}$ ; containing  $(-5, 3)$

$$y - y_1 = m(x - x_1)$$

$$y - 3 = \frac{2}{3}(x - (-5)) \rightarrow y - 3 = \frac{2}{3}x + \frac{10}{3}$$

$$y = \frac{2}{3}x + \frac{19}{3}$$

$$2x - 3y = -19 \text{ or } y = \frac{2}{3}x + \frac{19}{3}$$

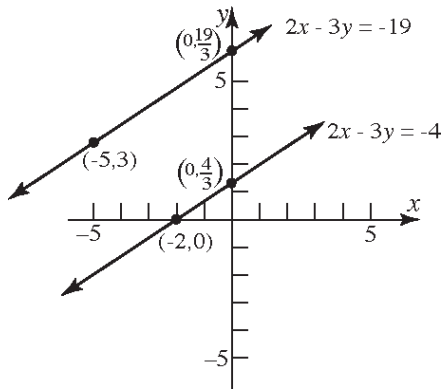

25. Perpendicular to  $3x - y = -4$ ;

Slope of perpendicular =  $-\frac{1}{3}$

Containing the point  $(-2, 4)$

$$y - y_1 = m(x - x_1)$$

$$y - 4 = -\frac{1}{3}(x - (-2))$$

$$y - 4 = -\frac{1}{3}x - \frac{2}{3}$$

$$y = -\frac{1}{3}x + \frac{10}{3}$$

$$x + 3y = 10 \text{ or } y = -\frac{1}{3}x + \frac{10}{3}$$

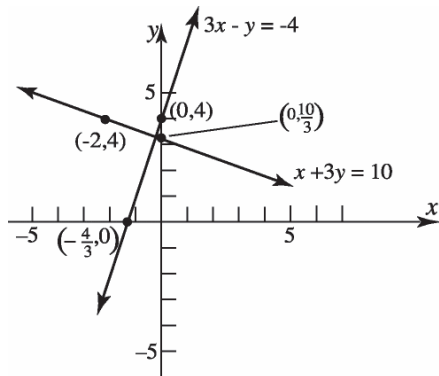

26.  $(x - h)^2 + (y - k)^2 = r^2$

$$(x - (-2))^2 + (y - 3)^2 = 4^2$$

$$(x + 2)^2 + (y - 3)^2 = 16$$

27.  $(x - h)^2 + (y - k)^2 = r^2$

$$(x - (-1))^2 + (y - (-2))^2 = 1^2$$

$$(x + 1)^2 + (y + 2)^2 = 1$$

28.  $x^2 + y^2 - 2x + 4y - 4 = 0$

$$x^2 - 2x + y^2 + 4y = 4$$

$$(x^2 - 2x + 1) + (y^2 + 4y + 4) = 4 + 1 + 4$$

$$(x - 1)^2 + (y + 2)^2 = 9$$

$$(x - 1)^2 + (y + 2)^2 = 3^2$$

Center:  $(1, -2)$  Radius = 3

$$x^2 + 0^2 - 2x + 4(0) - 4 = 0$$

$$x^2 - 2x - 4 = 0$$

$$x = \frac{-(-2) \pm \sqrt{(-2)^2 - 4(1)(-4)}}{2(1)} = \frac{2 \pm \sqrt{20}}{2}$$

$$= \frac{2 \pm 2\sqrt{5}}{2} = 1 \pm \sqrt{5}$$

$$0^2 + y^2 - 2(0) + 4y - 4 = 0$$

$$y^2 + 4y - 4 = 0$$

$$y = \frac{-4 \pm \sqrt{4^2 - 4(1)(-4)}}{2(1)} = \frac{-4 \pm \sqrt{32}}{2}$$

$$= \frac{-4 \pm 4\sqrt{2}}{2} = -2 \pm 2\sqrt{2}$$

Intercepts:

$(1 - \sqrt{5}, 0)$ ,  $(1 + \sqrt{5}, 0)$ ,  $(0, -2 - 2\sqrt{2})$ , and

$(0, -2 + 2\sqrt{2})$

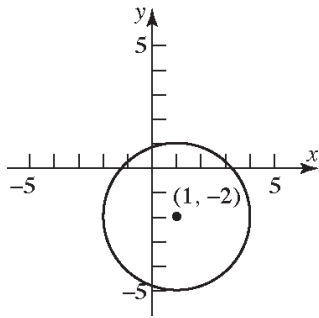

29.  $3x^2 + 3y^2 - 6x + 12y = 0$   
 $x^2 + y^2 - 2x + 4y = 0$   
 $x^2 - 2x + y^2 + 4y = 0$   
 $(x^2 - 2x + 1) + (y^2 + 4y + 4) = 1 + 4$   
 $(x-1)^2 + (y+2)^2 = 5$   
 $(x-1)^2 + (y+2)^2 = (\sqrt{5})^2$

Center: (1,-2) Radius =  $\sqrt{5}$

$3x^2 + 3(0)^2 - 6x + 12(0) = 0$   
 $3x^2 - 6x = 0$   
 $3x(x-2) = 0$   
 $x = 0$  or  $x = 2$

$3(0)^2 + 3y^2 - 6(0) + 12y = 0$   
 $3y^2 + 12y = 0$   
 $3y(y+4) = 0$   
 $y = 0$  or  $y = -4$

Intercepts:

(0,0), (2,0), and (0,-4)

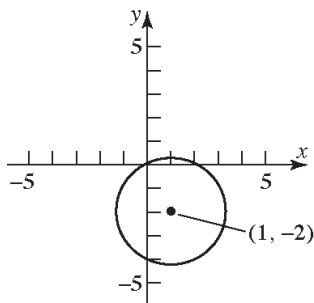

30. Given the points

$A = (-2, 0)$ ,  $B = (-4, 4)$ ,  $C = (8, 5)$ .

a. Find the distance between each pair of points.

$$d(A, B) = \sqrt{(-4 - (-2))^2 + (4 - 0)^2}$$

$$= \sqrt{4 + 16} = \sqrt{20} = 2\sqrt{5}$$

$$d(B, C) = \sqrt{(8 - (-4))^2 + (5 - 4)^2}$$

$$= \sqrt{144 + 1} = \sqrt{145}$$

$$d(A, C) = \sqrt{(8 - (-2))^2 + (5 - 0)^2}$$

$$= \sqrt{100 + 25} = \sqrt{125} = 5\sqrt{5}$$

$$(\sqrt{20})^2 + (\sqrt{125})^2 = (\sqrt{145})^2$$

$$20 + 125 = 145$$

$$145 = 145$$

The Pythagorean Theorem is satisfied, so this is a right triangle.

b. Find the slopes:

$$m_{AB} = \frac{4 - 0}{-4 - (-2)} = \frac{4}{-2} = -2$$

$$m_{BC} = \frac{5 - 4}{8 - (-4)} = \frac{1}{12}$$

$$m_{AC} = \frac{5 - 0}{8 - (-2)} = \frac{5}{10} = \frac{1}{2}$$

$$m_{AB} \cdot m_{AC} = -2 \cdot \frac{1}{2} = -1$$

Since the product of the slopes is  $-1$ , the sides of the triangle are perpendicular and the triangle is a right triangle.

31. slope of  $\overline{AB} = \frac{1-5}{6-2} = -1$ ;

slope of  $\overline{BC} = \frac{-1-1}{8-6} = -1$

Since lines  $AB$  and  $BC$  are parallel, and have a point in common (B), they are the same line. Therefore,  $A$ ,  $B$ , and  $C$  are collinear.

## Chapter 1: Graphs

32. A circle with center  $(-1, 2)$  has equation

$$(x+1)^2 + (y-2)^2 = r^2$$

point  $A(1, 5) \Rightarrow (1+1)^2 + (5-2)^2 = r^2$

$$4 + 9 = r^2 \Rightarrow r = \sqrt{13}$$

point  $B(2, 4) \Rightarrow (2+1)^2 + (4-2)^2 = r^2$

$$9 + 4 = r^2 \Rightarrow r = \sqrt{13}$$

point  $C(-3, 5) \Rightarrow (-3+1)^2 + (5-2)^2 = r^2$

$$4 + 9 = r^2 \Rightarrow r = \sqrt{13}$$

Therefore the points  $A$ ,  $B$  and  $C$  lie on a circle with center point  $(-1, 2)$  and radius  $= \sqrt{13}$ .

33. Endpoints of the diameter are  $(-3, 2)$  and  $(5, -6)$ . The center is at the midpoint of the diameter:

$$\text{Center: } \left( \frac{-3+5}{2}, \frac{2+(-6)}{2} \right) = (1, -2)$$

$$\text{Radius: } r = \sqrt{(1-(-3))^2 + (-2-2)^2} = \sqrt{16+16} \\ = \sqrt{32} = 4\sqrt{2}$$

$$\text{Equation: } (x-1)^2 + (y+2)^2 = (4\sqrt{2})^2$$

$$x^2 - 2x + 1 + y^2 + 4y + 4 = 32$$

$$x^2 + y^2 - 2x + 4y - 27 = 0$$

34. Using the distance formula on the points  $(-3, 2)$  and  $(5, y)$  yields

$$d = \sqrt{(5-(-3))^2 + (y-2)^2} = \sqrt{64 + (y-2)^2}$$

Now set  $d = 10$  and solve for  $y$ .

$$10 = \sqrt{64 + (y-2)^2}$$

$$10^2 = (\sqrt{64 + (y-2)^2})^2$$

$$100 = 64 + (y-2)^2$$

$$36 = (y-2)^2$$

$$\pm 6 = y - 2$$

$$\text{so } y - 2 = 6 \rightarrow y = 8$$

$$\text{and } y - 2 = -6 \rightarrow y = -4$$

35. slope  $= \frac{2}{3}$ , containing the point  $(1, 2)$

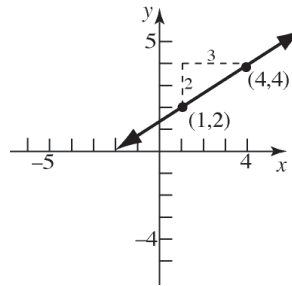

36. Answers will vary.

37. a.  $x = 0$  is a vertical line passing through the origin, that is,  $x = 0$  is the equation of the  $y$ -axis
- b.  $y = 0$  is a horizontal line passing through the origin, that is,  $y = 0$  is the equation of the  $x$ -axis
- c.  $x + y = 0$  implies that  $y = -x$ . Thus, the graph of  $x + y = 0$  is the line passing through the origin with slope  $= -1$ .
- d.  $xy = 0$  implies that either  $x = 0$ ,  $y = 0$ , or both are 0.  $x = 0$  is the  $y$ -axis and  $y = 0$  is the  $x$ -axis. Thus, the graph of  $xy = 0$  is a graph consisting of the coordinate axes.
- e.  $x^2 + y^2 = 0$  implies that both  $x = 0$  and  $y = 0$ . Thus, the graph of  $x^2 + y^2 = 0$  is a graph consisting of a single point - the origin.

## Chapter 1 Test

$$\begin{aligned} 1. \text{ a. } d &= \sqrt{(x_2 - x_1)^2 + (y_2 - y_1)^2} \\ &= \sqrt{(4 - (-2))^2 + (5 - (-3))^2} \\ &= \sqrt{6^2 + 8^2} \\ &= \sqrt{36 + 64} \\ &= \sqrt{100} \\ &= 10 \end{aligned}$$



b.  $M = \left( \frac{x_1 + x_2}{2}, \frac{y_1 + y_2}{2} \right)$   
 $= \left( \frac{4 + (-2)}{2}, \frac{5 + (-3)}{2} \right)$   
 $= \left( \frac{2}{2}, \frac{2}{2} \right)$   
 $= (1, 1)$

2.  $2x - 7y = 21$   
 $-7y = -2x + 21$   
 $y = \frac{2}{7}x - 3$

$x$	$y = \frac{2}{7}x - 3$	$(x, y)$
-7	$y = \frac{2}{7}(-7) - 3 = -5$	$(-7, -5)$
0	$y = \frac{2}{7}(0) - 3 = -3$	$(0, -3)$
7	$y = \frac{2}{7}(7) - 3 = -1$	$(7, -1)$

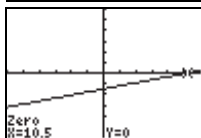
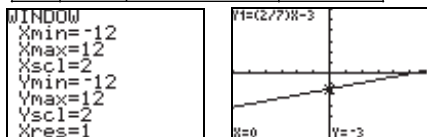

The intercepts are  $(0, -3)$  and  $(10.5, 0)$ .

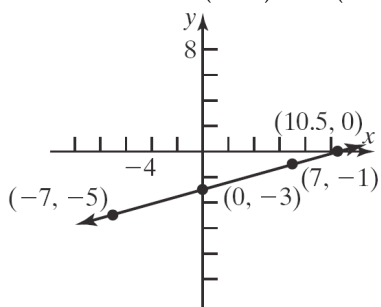

3.  $y = x^2 - 5$

$x$	$y = x^2 - 5$	$(x, y)$
-3	$y = (-3)^2 - 5 = 4$	$(-3, 4)$
-1	$y = (-1)^2 - 5 = -4$	$(-1, -4)$
0	$y = (0)^2 - 5 = -5$	$(0, -5)$
1	$y = (1)^2 - 5 = -4$	$(1, -4)$
3	$y = (3)^2 - 5 = 4$	$(3, 4)$

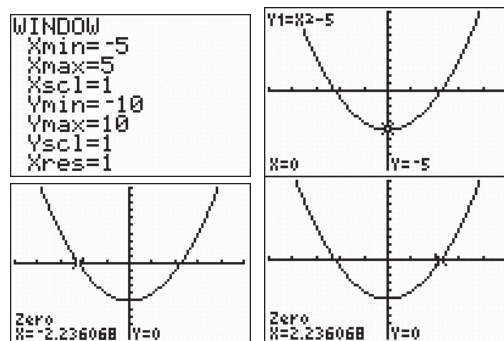

The intercepts are  $(0, -5)$ ,  $\approx (-2.24, 0)$ , and  $\approx (2.24, 0)$ .

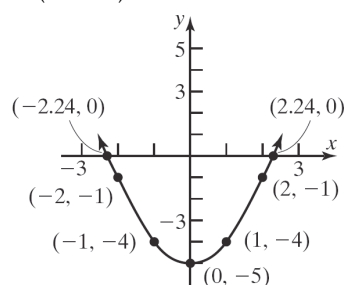

4.  $2x^3 - x^2 - 2x + 1 = 0$

Since this equation has 0 on one side, we will use the Zero option from the CALC menu. It will be important to carefully select the window settings so as not to miss any solutions.

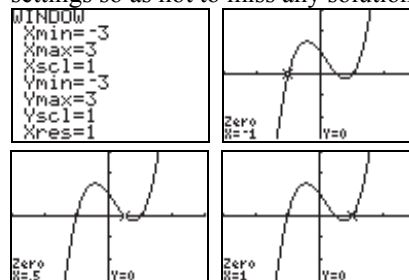

The solutions to the equation are  $-1$ ,  $0.5$ , and  $1$ .

5.  $x^4 - 5x^2 - 8 = 0$

Since this equation has 0 on one side, we will use the Zero option from the CALC menu.

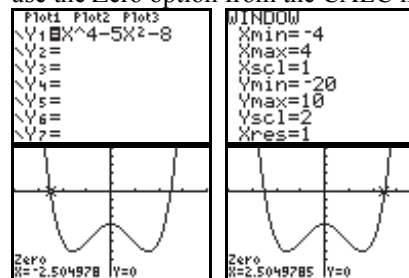

The solutions, rounded to two decimal places, are  $-2.50$  and  $2.50$ .

**Chapter 1: Graphs**

6.  $-x^3 + 7x - 2 = x^2 + 3x - 3$

Since there are nonzero expressions on both sides of the equation, we will use the Intersect option from the CALC menu. Enter the left side of the equation in Y1 and the right side in Y2.

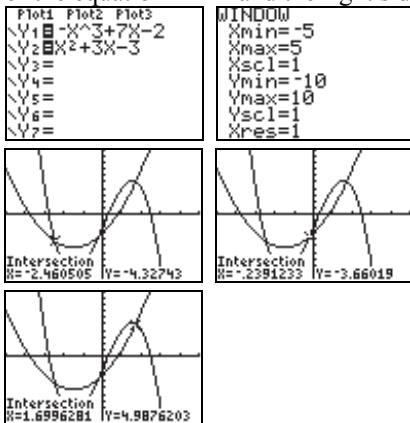

The solutions, rounded to two decimal places, are  $-2.46$ ,  $-0.24$ , and  $1.70$ .

7. a.  $m = \frac{y_2 - y_1}{x_2 - x_1} = \frac{-1 - 3}{5 - (-1)} = \frac{-4}{6} = -\frac{2}{3}$

b. If  $x$  increases by 3 units,  $y$  will decrease by 2 units.

8.  $y^2 = x$

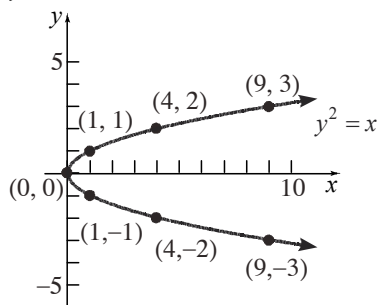

9.  $x^2 + y = 9$

$x$ -intercepts:  $x^2 + 0 = 9$   
 $x^2 = 9$   
 $x = \pm 3$

$y$ -intercept:  $(0)^2 + y = 9$   
 $y = 9$

The intercepts are  $(-3, 0)$ ,  $(3, 0)$ , and  $(0, 9)$ .

Test x-axis symmetry: Let  $y = -y$

$x^2 + (-y) = 9$   
 $x^2 - y = 9$  different

Test y-axis symmetry: Let  $x = -x$

$(-x)^2 + y = 9$   
 $x^2 + y = 9$  same

Test origin symmetry: Let  $x = -x$  and  $y = -y$

$(-x)^2 + (-y) = 9$   
 $x^2 - y = 9$  different

Therefore, the graph will have  $y$ -axis symmetry.

10. Slope =  $-2$ ; containing  $(3, -4)$

$y - y_1 = m(x - x_1)$   
 $y - (-4) = -2(x - 3)$   
 $y + 4 = -2x + 6$   
 $y = -2x + 2$

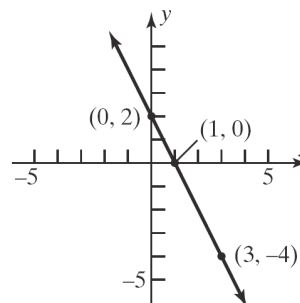

11.  $(x - h)^2 + (y - k)^2 = r^2$

$(x - 4)^2 + (y - (-3))^2 = 5^2$   
 $(x - 4)^2 + (y + 3)^2 = 25$

General form:

$(x - 4)^2 + (y + 3)^2 = 25$   
 $x^2 - 8x + 16 + y^2 + 6y + 9 = 25$   
 $x^2 + y^2 - 8x + 6y = 0$

## Chapter 1 Project

## Internet-based Project

$$\begin{aligned}
 12. \quad & x^2 + y^2 + 4x - 2y - 4 = 0 \\
 & x^2 + 4x + y^2 - 2y = 4 \\
 & (x^2 + 4x + 4) + (y^2 - 2y + 1) = 4 + 4 + 1 \\
 & (x + 2)^2 + (y - 1)^2 = 3^2
 \end{aligned}$$

Center:  $(-2, 1)$ ; Radius = 3

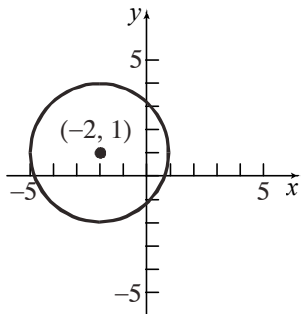

$$\begin{aligned}
 13. \quad & 2x + 3y = 6 \\
 & 3y = -2x + 6 \\
 & y = -\frac{2}{3}x + 2
 \end{aligned}$$

Parallel line

Any line parallel to  $2x + 3y = 6$  has slope

$$m = -\frac{2}{3}. \text{ The line contains } (1, -1):$$

$$y - y_1 = m(x - x_1)$$

$$y - (-1) = -\frac{2}{3}(x - 1)$$

$$y + 1 = -\frac{2}{3}x + \frac{2}{3}$$

$$y = -\frac{2}{3}x - \frac{1}{3}$$

Perpendicular line

Any line perpendicular to  $2x + 3y = 6$  has slope

$$m = \frac{3}{2}. \text{ The line contains } (0, 3):$$

$$y - y_1 = m(x - x_1)$$

$$y - 3 = \frac{3}{2}(x - 0)$$

$$y - 3 = \frac{3}{2}x$$

$$y = \frac{3}{2}x + 3$$