

2-1. Calculate the total uniformly distributed roof dead load in psf of horizontal plan area for a sloped roof with the design parameters given below.

- 2x8 rafters at 24" on centers
- Asphalt shingles on 1/2" plywood sheathing
- 6" insulation (fiberglass)
- Suspended Ceiling
- Roof slope: 6-in-12
- Mechanical & Electrical (i.e. ducts, plumbing etc) = 5 psf

Solution:

2x8 rafters at 24" on-centers	= 1.2 psf
Asphalt shingles (assume 1/4" shingles)	= 2.0 psf
1/2" plywood sheathing = (4 x 0.4 psf/1/8" plywood)	= 1.6 psf
6" insulation (fiberglass) = 6 x 1.1 psf/in.	= 6.6 psf
Suspended Ceiling	= 2.0 psf
Mechanical & Electrical (i.e. ducts, plumbing etc)	= 5.0 psf

Total roof dead load, D (psf of sloped roof area) = 18.4 psf

The total dead load in psf of horizontal plan area will be:

$$w_{DL} = D \left(\frac{\sqrt{6^2 + 12^2}}{12} \right), \text{ psf of horizontal plan area}$$

$$= 18.4 \text{ psf} (1.118) = 20.6 \text{ psf of horizontal plan area}$$

2-2. Given the following design parameters for a sloped roof, calculate the uniform total load and the maximum shear and moment on the rafter. Calculate the horizontal thrust on the exterior wall if rafters are used.

- Roof dead load, $D = 20$ psf (of sloped roof area)
- Roof snow load, $S = 40$ psf (of horizontal plan area)
- Horizontal projected length of rafter, $L_2 = 14$ ft
- Roof slope: 4-in-12
- Rafter or Truss spacing = 4' 0"

Solutions:

$$\text{Sloped length of rafter, } L_1 = \left(\frac{\sqrt{4^2 + 12^2}}{12} \right) (14 \text{ ft}) = 14.8 \text{ ft}$$

Using the load combinations in section 2.1, the total load in psf of horizontal plan area will be:

$$\begin{aligned} w_{TL} &= D \left(\frac{L_1}{L_2} \right) + (L_r \text{ or } S \text{ or } R), \text{ psf of horizontal plan area} \\ &= 20 \text{ psf} \left(\frac{14.8'}{14'} \right) + 40 \text{ psf} \\ &= \mathbf{61.1 \text{ psf}} \text{ of horizontal plan area} \end{aligned}$$

The total load in pounds per horizontal linear foot (lb/ft) is given as,
 w_{TL} (lb/ft) = w_{TL} (psf) x Tributary width (TW) or Spacing of rafters
 = 61.1 psf (4 ft) = **244.4 lb/ft.**

$$h = (4/12) (14 \text{ ft}) = 4.67 \text{ ft}$$

The horizontal thrust H is,

$$H = \frac{w_{TL} (L_2) \left(\frac{L_2}{2} \right)}{h} = \frac{244.4 \text{ lb/ft} (14') \left(\frac{14'}{2} \right)}{4.67'} = 5129 \text{ lb.}$$

The collar or ceiling ties must be designed to resist this horizontal thrust.

$$L_2 = 14'$$

The maximum shear force in the rafter is,

$$V_{\max} = w_{TL} \left(\frac{L_2}{2} \right) = 244.4 \left(\frac{14'}{2} \right) = 1711 \text{ lb}$$

The maximum moment in the rafter is,

$$M_{\max} = \frac{w_{TL} (L_2)^2}{8} = \frac{244.4 (14')^2}{8} = 5989 \text{ ft-lb} = 5.9 \text{ ft-kip}$$

2-3. Determine the tributary widths and tributary areas of the joists, beams, girders and columns in the panelized roof framing plan shown below. Assuming a roof dead load of 20 psf and an essentially flat roof with a roof slope of 1/4" per foot for drainage, determine the following loads using the IBC load combinations. Neglect the rain load, R and assume the snow load, S is zero:

- The uniform total load on the typical roof joist in lb/ft
- The uniform total load on the typical roof girder in lb/ft
- The total axial load on the typical interior column, in lb.
- The total axial load on the typical perimeter column, in lb

Solution:

The solution is presented in a tabular format as shown below:

Tributary Widths and Tributary Areas of Joists, Beams and Columns

Structural Member	Tributary Width (TW)	Tributary Area (TA)
Purlin	$\frac{10'}{2} + \frac{10'}{2} = 10'$	$10' \times 20' = 200 \text{ ft}^2$
Glulam girder	$\frac{20'}{2} + \frac{20'}{2} = 20'$	$20' \times 60' = 1200 \text{ ft}^2$
Typical interior Column		$\left(\frac{20'}{2} + \frac{20'}{2}\right)\left(\frac{60'}{2} + \frac{60'}{2}\right) = 1200 \text{ ft}^2$
Typical perimeter Column		$\left(\frac{20'}{2} + \frac{20'}{2}\right)\left(\frac{60'}{2}\right) = 600 \text{ ft}^2$

Since the snow and rain load are both zero, the roof live load, L_r will be critical.
With a roof slope of $\frac{1}{4}$ " per foot, the number of inches of rise per foot, $F = \frac{1}{4} = 0.25$

Purlin:

The tributary width $TW = 10 \text{ ft}$ and the tributary area, $TA = 200 \text{ ft}^2 < 200 \text{ ft}^2$
From section 2.5.1, we obtain: $R_1 = 1.0$ and $R_2 = 1.0$,

Using equation 2-4 gives the roof live load, $L_r = 20 \times 1 \times 1 = 20 \text{ psf}$

The total loads are calculated as follows:

$$w_{TL} \text{ (psf)} = (D + L_r) = 20 + 20 = 40 \text{ psf}$$

$$w_{TL} \text{ (Ib/ft)} = w_{TL} \text{ (psf)} \times \text{tributary width (TW)} = 40 \text{ psf} \times 10 \text{ ft} = 400 \text{ Ib/ft}$$

Glulam Girder:

The tributary width, $TW = 20 \text{ ft}$ and the tributary Area, $TA = 1200 \text{ ft}^2$
Thus, $TA > 600$, and from section 2.4, we obtain:

$$R_1 = 0.6, \text{ and}$$

$$R_2 = 1.0$$

Using equation 2-4 gives the roof live load, $L_r = 20 \times 0.6 \times 1 = 12 \text{ psf}$

The total loads are calculated as follows:

$$w_{TL} \text{ (psf)} = (D + L_r) = 20 + 12 = 32 \text{ psf}$$

$$w_{TL} \text{ (Ib/ft)} = w_{TL} \text{ (psf)} \times \text{tributary width (TW)} = 32 \text{ psf} \times 20 \text{ ft} = 640 \text{ Ib/ft}$$

Typical Interior Column:

The tributary tributary area of the typical interior column, $TA = 1200 \text{ ft}^2$
Thus, $TA > 600$, and from section 2.4, we obtain:

$$R_1 = 0.6, \text{ and}$$

$$R_2 = 1.0$$

Using equation 2-4 gives the roof live load, $L_r = 20 \times 0.6 \times 1 = 12 \text{ psf}$

The total loads are calculated as follows:

$$w_{TL} \text{ (psf)} = (D + L_r) = 20 + 12 = 32 \text{ psf}$$

The Column Axial Load, $P = 32 \text{ psf} \times 1200 \text{ ft}^2 = 38,400 \text{ lb} = 38.4 \text{ kips}$

Typical Perimeter Column:

The tributary tributary area of the typical perimeter column, $TA = 600 \text{ ft}^2$
Thus, from section 2.5.1, we obtain:

$$R_1 = 0.6, \text{ and}$$

$$R_2 = 1.0$$

Using equation 2-4 gives the roof live load, $L_r = 20 \times 0.6 \times 1 = 12 \text{ psf}$

The total loads are calculated as follows:

$$w_{TL} \text{ (psf)} = (D + L_r) = 20 + 12 = 32 \text{ psf}$$

The Column Axial Load, $P = 32 \text{ psf} \times 600 \text{ ft}^2 = 19,200 \text{ lb} = 19.2 \text{ kips}$

2-4. *A building has sloped roof rafters (5:12 slope) spaced at 2' 0" on centers and is located in Hartford, Connecticut. The roof dead load is 22 psf of sloped area. Assume a fully exposed roof with terrain category "C", and use the ground snow load from the IBC or ASCE 7 snow map*

(a) *Calculate the total uniform load in lb/ft on a horizontal plane using the IBC.*

(b) *Calculate the maximum shear and moment in the roof rafter.*

Solution:

The roof slope, θ for this building is 22.6° ,

Roof Live Load, L_r :

From Section 2.4, the roof slope factor is obtained as,

$$F = 5 \quad \therefore R_2 = 1.2 - 0.05(5) = 0.95$$

Assume the tributary area (TA) of the rafter $< 200 \text{ ft}^2$,

$$\therefore R_1 = 1.0$$

The roof live load will be,

$$L_r = 20R_1R_2 = 20(1.0)(0.95) = 19 \text{ psf}$$

Snow Load:

Using IBC Figure 1608.2 or ASCE 7 Figure 7-1, the ground snow load, P_g for Hartford, Connecticut is 30 psf.

Assuming a building with a warm roof and fully exposed, and a building site with terrain category "C", we obtain the coefficients as follows:

Exposure coefficient, $C_e = 0.9$ (ASCE 7 Table 7-2)

The thermal factor, $C_t = 1.0$ (ASCE 7 Table 7-3)

The Importance Factor, $I = 1.0$ ASCE Table 7-4

The slope factor, $C_s = 1.0$ (ASCE Figure 7-2 with roof slope, $\theta = 22.6^\circ$ and a warm roof)

The flat roof snow load, $P_f = 0.7 C_e C_t I P_g = 0.7 \times 0.9 \times 1.0 \times 1.0 \times 30 = 18.9$ psf

Minimum flat roof snow load, $P_m = 20I_s = 20(1.0) = 20$ psf (governs)

Thus, the design roof snow load, $P_s = C_s P_f = 1.0 \times 20 = 20$ psf

Therefore, the snow load, $S = 20$ psf

The total load in psf of horizontal plan area is given as,

$$w_{TL} = D \left(\frac{L_1}{L_2} \right) + (L_r \text{ or } S \text{ or } R), \text{ psf of horizontal plan area}$$

Since the roof live load, L_r (18 psf) is smaller than the snow load, S (20 psf), the snow load is more critical and will be used in calculating the total roof load.

$$\begin{aligned} w_{TL} &= 22 \text{ psf} \left(\frac{\sqrt{5^2 + 12^2}}{12} \right) + 20 \text{ psf} \\ &= \mathbf{43.83 \text{ psf}} \text{ of horizontal plan area} \end{aligned}$$

The total load in pounds per horizontal linear foot (lb/ft) is given as,

$$\begin{aligned} w_{TL} \text{ (lb/ft)} &= w_{TL} \text{ (psf)} \times \text{Tributary width (TW) or Spacing of rafters} \\ &= 43.83 \text{ psf} (2 \text{ ft}) = \mathbf{87.7 \text{ lb/ft.}} \end{aligned}$$

Assume $L_2 = 14'$

The maximum moment in the rafter is,

$$M_{\max} = \frac{w_{TL}(L_2)^2}{8} = \frac{87.7(14')^2}{8} = 2149 \text{ ft-lb} = 2.15 \text{ ft-kip}$$

- 2-5.** A 3-story building has columns spaced at 18 ft in both orthogonal directions, and is subjected to the roof and floor loads shown below. Using a column load summation table, calculate the cumulative axial loads on a typical interior column with and without live load reduction. Assume a roof slope of $\frac{1}{4}$ " per foot for drainage.

Roof Loads:

Dead Load, $D_{\text{roof}} = 20$ psf

Snow Load, $S = 40$ psf

2nd and 3rd Floor Loads:

Dead Load, $D_{\text{floor}} = 40$ psf

Floor Live Load, $L = 50$ psf

Solution:

At each level, the tributary area (TA) supported by a typical interior column is

$$18' \times 18' = 324 \text{ ft}^2$$

Roof Live Load, L_r :

From section 2.4, the roof slope factor is obtained as,

$$F = \frac{1}{4} = 0.25 \quad \therefore R_2 = 1.0$$

Since the tributary area (TA) of the column = 324 ft^2 , $\therefore R_1 = 1.2 - 0.001(324) = 0.88$

The roof live load will be,

$$L_r = 20R_1R_2 = 20(0.88)(1.0) = 17.6 \text{ psf} < \text{Snow load, } S = 40 \text{ psf}$$

The governing load combination from Section 2.1.1 for calculating the column axial loads is $D + L + (L_r \text{ or } S \text{ or } R)$. Since the snow load is greater than the roof live load, the critical load combination reduces to $D + L + S$.

The reduced or design floor live load for the 2nd and 3rd floors are calculated using the table below:

Reduced or Design Floor Live Load Calculation Table

Member	Levels supported	A_T (summation of floor tributary area)	K_{LL}	Unreduced Floor live load, L_o (psf)	Live Load Reduction Factor $0.25 + \frac{15}{\sqrt{(K_{LL} A_T)}}$	Design floor live load, L

3rd floor Column (i.e. column below roof)	Roof only	Floor live load reduction NOT applicable to roofs!!!	-	-	-	40 psf (Snow load)
2nd floor column (i.e. column below 3 rd floor)	1 floor + roof	1 floor x 324 ft ² = 324 ft²	4 K _{LL} A _T = 1296 > 400 ft ² ∴ Live Load reduction allowed	50 psf	0.25 + 15/√(4 x 324) = 0.67	0.67 x 50 = 33.5 psf ≥ 0.50 Lo = 25 psf
Ground or 1st floor column (i.e. column below 2 nd floor)	2 floors + roof	2 floors x 324 ft ² = 648 ft²	4 K _{LL} A _T = 2592 > 400 ft ² ∴ Live Load reduction allowed	50 psf	0.25 + 15/√(4 x 648) = 0.54	0.54 x 50 = 27 psf ≥ 0.40 Lo = 20 psf

The column axial loads with and without floor live load reduction are calculated using the column load summation tables below:

Column Load Summation Table

Level	Tributary area, (TA) (ft ²)	Dead Load, <i>D</i> (psf)	Live Load, <i>L_o</i> (<i>S</i> or <i>L_r</i> or <i>R</i> on the roof) (psf)	Design Live Load Roof: <i>S</i> or <i>L_r</i> or <i>R</i> Floor: <i>L</i> (psf)	Unfactored total load at each level, <i>w_{s1}</i> Roof: <i>D</i> Floor: <i>D + L</i> (psf)	Unfactored total load at each level, <i>w_{s2}</i> Roof: <i>D+0.75S</i> Floor: <i>D+0.75L</i> (psf)	Unfactored Column Axial Load at each level, <i>P = (TA)(w_{s1})</i> or <i>(TA)(w_{s2})</i> (kips)	Cumulative Unfactored Axial Load, ΣP_{D+L} (kips)	Cumulative Unfactored Axial Load, $\Sigma P_{D+0.75L+0.75S}$ (kips)	Maximum Cumulative Unfactored Axial Load, ΣP (kips)
With Floor Live Load Reduction										
Roof	324	20	40	40	20	50	6.5 or 16.2	6.5	16.2	16.2
3 rd Flr	324	40	50	33.5	73.5	65.1	23.8 or 21.1	30.3	37.3	37.3
2 nd Flr	324	40	50	27	67	60.3	21.7 or 19.5	52	56.8	56.8
Without Floor Live Load Reduction										
Roof	324	20	40	40	20	50	6.5 or 16.2	6.5	16.2	16.2
Third floor	324	40	50	50	90	77.5	29.2 or 25.1	35.7	41.3	41.3
Second floor	324	40	50	50	90	77.5	29.2 or 25.1	64.9	66.4	66.4

- 2-6.** A 2-story wood framed structure 36 ft x 75 ft in plan is shown below with the following given information. The floor to floor height is 10 ft and the truss bearing (or roof datum) elevation is at 20 ft and the truss ridge is 28 ft 4" above the ground floor level. The building is "enclosed" and located in Rochester, New York on a site with a category "C" exposure. Assuming the following additional design parameters, calculate:

$$\begin{aligned} \text{Floor Dead Load} &= 30 \text{ psf} \\ \text{Roof Dead Load} &= 20 \text{ psf} \\ \text{Exterior Walls} &= 10 \text{ psf} \\ \text{Snow Load } (P_f) &= 40 \text{ psf} \end{aligned}$$

$$\begin{aligned} \text{Site Class} &= D \\ \text{Importance } (I_e) &= 1.0 \\ S_s &= 0.25\% \\ S_l &= 0.07\% \\ R &= 6.5 \end{aligned}$$

- The total horizontal wind force on the main wind force resisting system (MWFRS) in both the transverse and longitudinal directions.
- The gross vertical wind uplift pressures and the net vertical wind uplift pressures on the roof (MWFRS) in both the transverse and longitudinal directions.
- The seismic base shear, V , in kips
- The lateral seismic load at each level in kips

Solution:

- (a) Lateral Wind

$$\text{Roof Slope: Run} = 18', \text{ Rise} = 8'-4'', \theta = 25^\circ$$

Assuming a Category II building

$$V = 115 \text{ mph (ASCE 7 Table 26.5-1A)}$$

Wind Pressures (from ASCE 7, Figure 28.6-1):

Transverse ($\theta = 25^\circ$):

<u>Horizontal</u>	<u>Vertical</u>
Zone A: 26.3 psf	Zone E: -11.7 psf
Zone B: 4.2 psf	Zone F: -15.9 psf
Zone C: 19.1 psf	Zone G: -8.5 psf
Zone D: 4.3 psf	Zone H: -12.8 psf

Longitudinal: ($\theta = 0^\circ$):

Horizontal

Zone A: 21 psf

Zone B: N/A

Zone C: 13.9 psf

Zone D: N/A

Vertical

Zone E: -25.2 psf

Zone F: -14.3 psf

Zone G: -17.5 psf

Zone H: -11.1 psf

End Zone width:

- a: $\leq 0.1 \times$ least horizontal dimension of building
 $\leq 0.4 \times$ mean roof height of the building and
 $\geq 0.04 \times$ least horizontal dimension of building
 ≥ 3 feet

- a $\leq 0.1 (36') = 3.6'$ (governs)
 $\leq (0.4) \left(\frac{20' + 28.33'}{2} \right) = 9.67'$
 $\geq 0.04 (36') = 1.44'$
 ≥ 3 feet

Therefore the Edge Zone = $2a = 2 (3.6') = 7.2'$

Average horizontal pressures:

Transverse:

$$q_{avg} = \left(\frac{(\text{end zone})(\text{end zone pressure}) + (\text{bldg width} - \text{end zone})(\text{interior zone pressure})}{(\text{bldg width})} \right)$$

$$q_{avg}(\text{wall}) = \left(\frac{(7.2')(26.3 \text{ psf}) + (75' - 7.2')(19.1 \text{ psf})}{(75')} \right) = 19.8 \text{ psf (Zones A, C)}$$

$$q_{avg}(\text{roof}) = \left(\frac{(7.2')(4.2 \text{ psf}) + (75' - 7.2')(4.3 \text{ psf})}{(75')} \right) = 4.3 \text{ psf (Zones B, D)}$$

Longitudinal:

$$q_{avg}(wall) = \left(\frac{(7.2')(21psf) + (36' - 7.2')(13.9psf)}{(36')} \right) = 15.32 \text{ psf (Zones A, C)}$$

Design wind pressures:

Height and exposure coefficient:

$$\text{Mean roof height} = \left(\frac{20' + 28.33'}{2} \right) = 24.2'$$

$$\lambda = 1.35 \text{ (ASCE 7 Figure 28.6-1, Exposure = C, } h \approx 25')$$

Transverse wind:

$$P = q_{avg}\lambda$$

$$P_{wall} = (19.8 \text{ psf})(1.35) = 26.73 \text{ psf}$$

$$P_{roof} = (4.3 \text{ psf})(1.35) = 5.81 \text{ psf}$$

Longitudinal wind:

$$P_{wall} = (15.32 \text{ psf})(1.35) = 20.7 \text{ psf}$$

Total Wind Force:

Transverse wind:

$$P_T = [(26.73 \text{ psf})(10' + 10') + (5.81 \text{ psf})(8.33')] (75') = \mathbf{43.7 \text{ kips}} \text{ (base shear, transverse)}$$

Longitudinal wind:

$$P_T = \left(20' + \frac{8.33'}{2} \right) (20.7 \text{ psf})(36') = \mathbf{18.0 \text{ kips}} \text{ (base shear, longitudinal)}$$

(b) Wind Uplift

Average vertical pressures:

$$P = q_{\text{avg}}\lambda$$

From Part (a), base uplift pressures:

<i>Transverse:</i>	<i>Longitudinal:</i>
Zone E: -11.7 psf	Zone E: -25.2 psf
Zone F: -15.9 psf	Zone F: -14.3 psf
Zone G: -8.5 psf	Zone G: -17.5 psf
Zone H: -12.8 psf	Zone H: -11.1 psf

Transverse:

$$P_{u,\text{avg}} = \left[(-11.7 \text{ psf} - 15.9 \text{ psf})(7.2') \left(\frac{36'}{2} \right) + (-8.5 \text{ psf} - 12.8 \text{ psf})(75' - 7.2') \left(\frac{36'}{2} \right) \right] \quad (1.35)$$

$$= -39,922 \text{ lb.}$$

$$q_{u,\text{avg}} = \frac{-39,922 \text{ lb}}{(75')(36')} = -14.8 \text{ psf (gross uplift, transverse)}$$

Longitudinal:

$$P_{u,\text{avg}} = \left[(-25.2 \text{ psf} - 14.3 \text{ psf})(7.2') \left(\frac{75'}{2} \right) + (-17.5 \text{ psf} - 11.1 \text{ psf})(36' - 7.2') \left(\frac{75'}{2} \right) \right] \quad (1.35)$$

$$= -56,097 \text{ lb.}$$

$$q_{u,\text{avg}} = \frac{-56,097 \text{ lb}}{(75')(36')} = -20.8 \text{ psf (gross uplift, longitudinal)}$$

Net factored uplift (Longitudinal controls):

$$q_{\text{net}} = 0.9D + W$$

$$= (0.9)(20 \text{ psf}) + (-20.8 \text{ psf}) = -2.8 \text{ psf (net uplift)}$$

(c) Seismic base shear

Calculate “W” for each level

Level	Area (ft. ²)	Trib. Height (ft.)	Wt. Level (kip)*	Wt. Walls (kip)	W _{total} (kip)
Roof	75' x 36' = 2700 ft.²	(10'/2)= 5'	(2700 ft ²) x [20psf + (0.2x40psf)] = 75.6k	(5') x (10psf) x (2) x (75' + 36') = 11.1k	75.6k + 11.1k = 86.7k
2 nd	75' x 36' = 2700 ft.²	(10'/2) + (10'/2) = 10'	(2700 ft ²) x (30psf) = 81.0k	(10') x (10psf) x (2) x (75' + 36') = 22.2k	81.0k + 22.2k = 103.2k
				$\Sigma W = 86.7k + 103.2k =$ 189.9k	

* Note: Where the flat roof snow load, P_f , is greater than 30psf, then 20% of the flat roof snow load shall be included in “W” for the roof (ASCE 7 Section 12.14.8.1)

Seismic Variables:

$$F_a = 1.6 \text{ (ASCE 7 Table 11.4-1)}$$

$$F_v = 2.4 \text{ (ASCE 7 Table 11.4-2)}$$

$$S_{MS} = F_a S_S = (1.6) (0.25) = 0.40$$

$$S_{M1} = F_a S_1 = (2.4) (0.07) = 0.168$$

$$S_{DS} = (2/3) S_{MS} = (2/3) (0.40) = \mathbf{0.267}$$

$$S_{D1} = (2/3) S_{M1} = (2/3) (0.168) = \mathbf{0.112}$$

Base Shear:

$$V = \frac{F S_{DS} W}{R}$$

$$V = \frac{(1.1)(0.267)(189.9)}{(6.5)} = \mathbf{8.58k}$$

(d) Seismic Forces at each level:

$$F_x = \frac{FS_{DS} W_x}{R}$$

$$F_R = \frac{(1.1)(0.267)(86.7)}{(6.5)} = \mathbf{3.92k}$$

$$F_2 = \frac{(1.1)(0.267)(103.2)}{(6.5)} = \mathbf{4.67k}$$

....

2-7 (see framing plan and floor section)

- Determine the floor dead load in PSF
- Determine the service dead and live loads to J-1 and G-1 in PLF
- Determine the maximum factored loads in PLF to J-1 and G-1
- Determine the factored maximum moment and shear in J-1 and G-1
- Determine the maximum service and factored load in kips to C-1

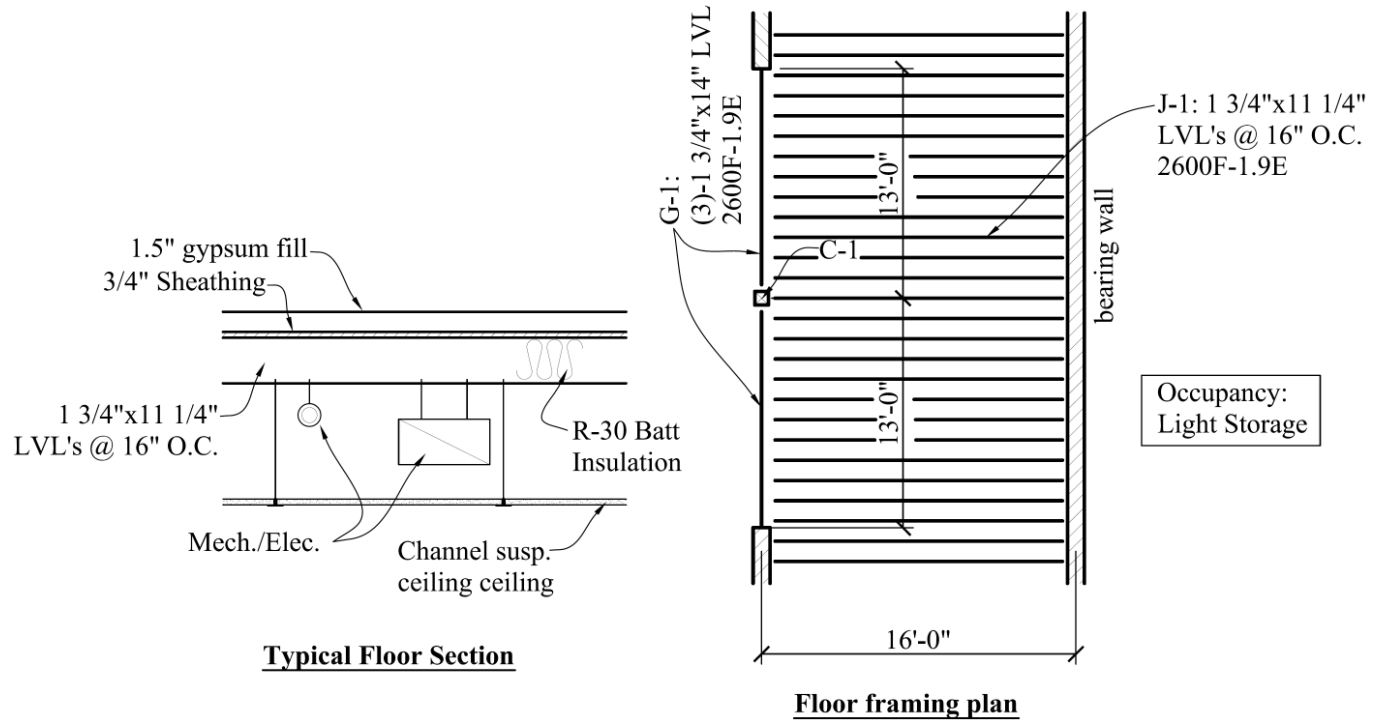

Dead Loads

$$w_{\text{gyp}} := (1.5\text{in}) \cdot \left(6 \frac{\text{lb}}{\text{ft}^2 \cdot \text{in}} \right) = 9 \cdot \text{psf}$$

$$LL := 125\text{psf}$$

$$w_{\text{sht}} := (0.75\text{in})(0.4\text{psf}) \left(\frac{1}{0.125\text{in}} \right) = 2.4 \cdot \text{psf}$$

$$w_{\text{ME}} := 5\text{psf} \quad w_{\text{ins}} := 4\text{psf} \quad w_{\text{clg}} := 2\text{psf}$$

$$w_{\text{LVL}} := \frac{(5.7\text{plf})}{1.33\text{ft}} = 4.286 \cdot \text{psf}$$

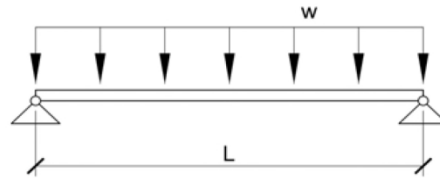

$$DL := w_{\text{gyp}} + w_{\text{sht}} + w_{\text{ME}} + w_{\text{ins}} + w_{\text{clg}} + w_{\text{LVL}} = 26.7 \cdot \text{psf} \quad \text{part a}$$

Loads to J-1:

$$L_j := 16\text{ft}$$

$$TW_j := 16\text{in}$$

$$w_{Dj} := TW_j \cdot DL = 35.6 \cdot \text{plf}$$

$$w_{Lj} := TW_j \cdot LL = 166.7 \cdot \text{plf}$$

$$w_{Sj} := w_{Dj} + w_{Lj} = 202.2 \cdot \text{plf} \quad \text{part b}$$

$$w_{uj} := (1.2)(w_{Dj}) + (1.6)(w_{Lj}) = 309 \cdot \text{plf} \quad \text{part c}$$

$$M_{Sj} := \frac{w_{Sj} \cdot L_j^2}{8} = 6472 \cdot \text{ft} \cdot \text{lb}$$

$$V_{Sj} := \frac{w_{Sj} \cdot L_j}{2} = 1618 \text{ lbf}$$

$$M_{uj} := \frac{w_{uj} \cdot L_j^2}{8} = 9900 \cdot \text{ft} \cdot \text{lb}$$

part d

$$V_{uj} := \frac{w_{uj} \cdot L_j}{2} = 2474.9 \text{ lbf}$$

Load to C-1:

$$P_s := 2 \cdot V_{SG} = 16052 \text{ lbf}$$

Loads to G-1:

$$L_G := 13\text{ft}$$

$$TW_G := 8\text{ft}$$

$$w_{DG} := TW_G \cdot DL + (3) \cdot (7.1\text{plf}) = 234.8 \cdot \text{plf}$$

$$w_{LG} := TW_G \cdot LL = 1000 \cdot \text{plf}$$

$$w_{SG} := w_{DG} + w_{LG} = 1234.8 \cdot \text{plf} \quad \text{part b}$$

$$w_{uG} := (1.2)(w_{DG}) + (1.6)(w_{LG}) = 1882 \cdot \text{plf} \quad \text{part c}$$

$$M_{SG} := \frac{w_{SG} \cdot L_G^2}{8} = 26085 \cdot \text{ft} \cdot \text{lb}$$

$$V_{SG} := \frac{w_{SG} \cdot L_G}{2} = 8026 \text{ lbf}$$

$$M_{uG} := \frac{w_{uG} \cdot L_G^2}{8} = 39752 \cdot \text{ft} \cdot \text{lb}$$

Service Loads

$$V_{uG} := \frac{w_{uG} \cdot L_G}{2} = 12231 \text{ lbf}$$

Factored Loads
part d

$$P_u := 2 \cdot V_{uG} = 24463 \text{ lbf} \quad \text{part e}$$

Problem 2.8

$$b := 1.875\text{in} \quad d := 12.5\text{in} \quad \underline{G} := 0.5$$

$$A_x := b \cdot d = 23.438 \cdot \text{in}^2$$

$$S_x := \frac{b \cdot d^2}{6} = 48.8 \cdot \text{in}^3$$

$$I_x := \frac{b \cdot d^3}{12} = 305.2 \cdot \text{in}^4$$

part a

$$\underline{w_{\text{self}}} := A_x \cdot G \cdot 62.4 \text{pcf} = 5.1 \cdot \text{plf}$$

part b

$$L_b := 17\text{ft}$$

$$TW := 16\text{in}$$

$$DL := 15\text{psf}$$

$$LL := 40\text{psf}$$

$$w_{DL} := TW \cdot DL + w_{\text{self}} = 25.1 \cdot \text{plf}$$

$$w_{LL} := LL \cdot TW = 53.3 \cdot \text{plf}$$

$$w_{TL} := w_{DL} + w_{LL} = 78.4 \cdot \text{plf}$$

$$M_b := \frac{w_{TL} \cdot L_b^2}{8} = 2833 \cdot \text{ft} \cdot \text{lb}$$

$$V_b := \frac{w_{TL} \cdot L_b}{2} = 666.497 \text{lb}$$

part c

$$f_b := \frac{M_b}{S_x} = 696.1 \text{psi}$$

part d

2-9. $w = 500\text{plf}$; $L_1 = 20\text{ft}$

Case 1: continuous over support

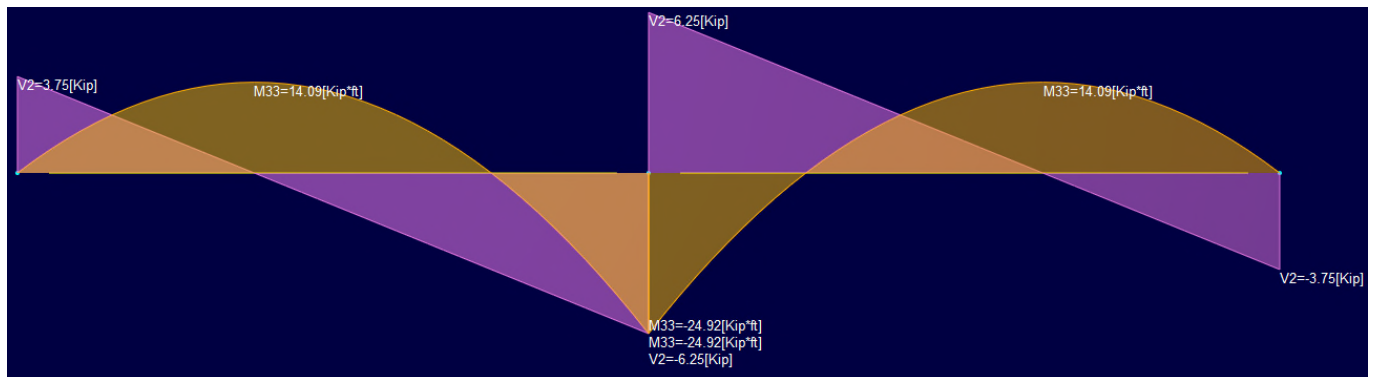
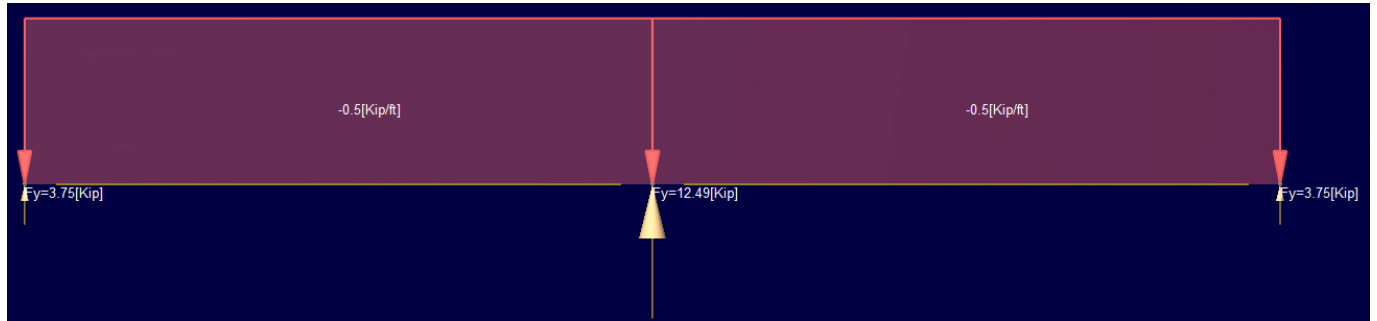

Case 2: hinged over support

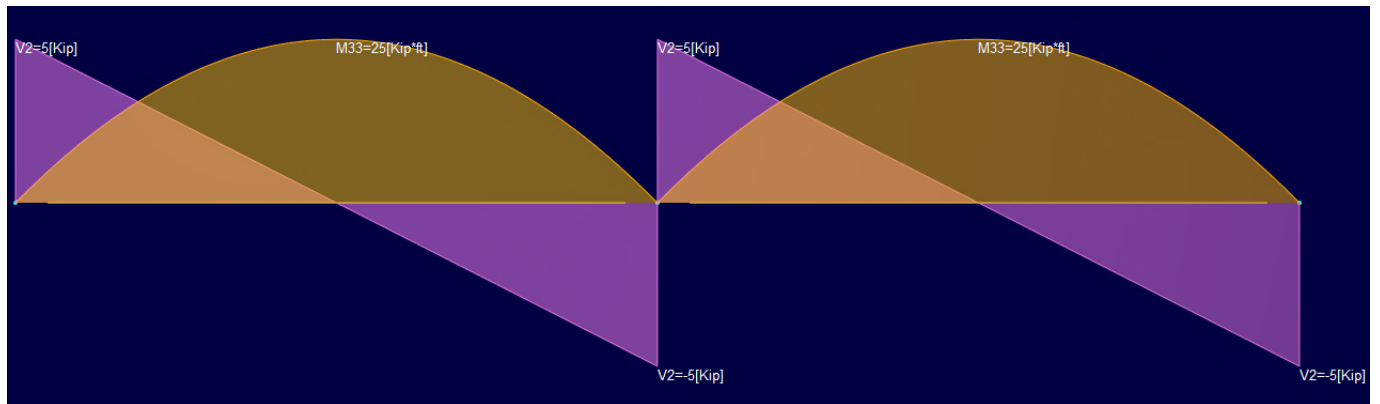
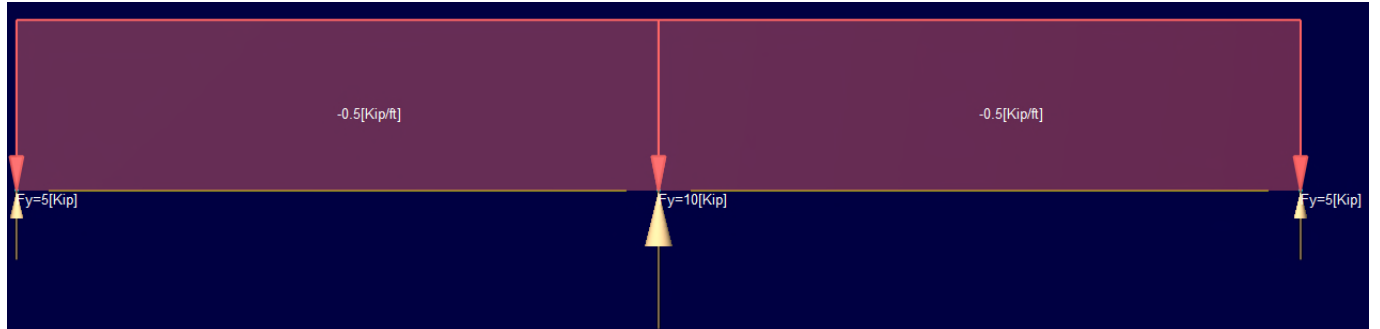

Case 1 would have less deflection

Case 2 is easier to build; 40ft section might be hard to get or ship/handle on-site

2-10

Job	Truss	Truss Type	Qty	Ply	Job Reference (optional)
VESTAL ROOF	M01	Monopitch Truss	1	1	

Stark Truss Inc., Canton, OH

ID:OU7J6iS03dRR9ldxfYFreyUmUC-wrT9RJYWRQwW2ppzJT1KqbCJbQ25NWRf9iPwhTyUS2i
7.250 s Mar 23 2011 MITek Industries, Inc. Tue Oct 11 16:17:21 2011 Page 1

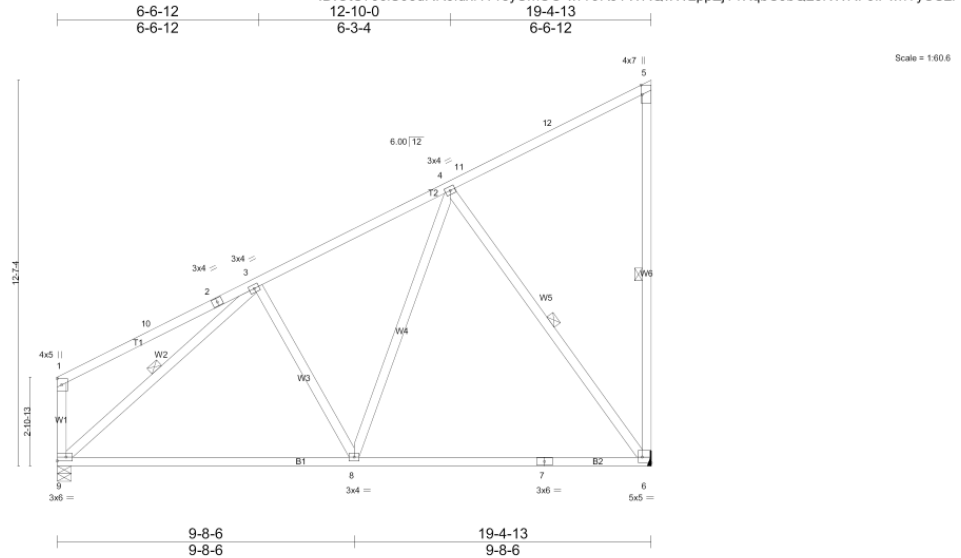
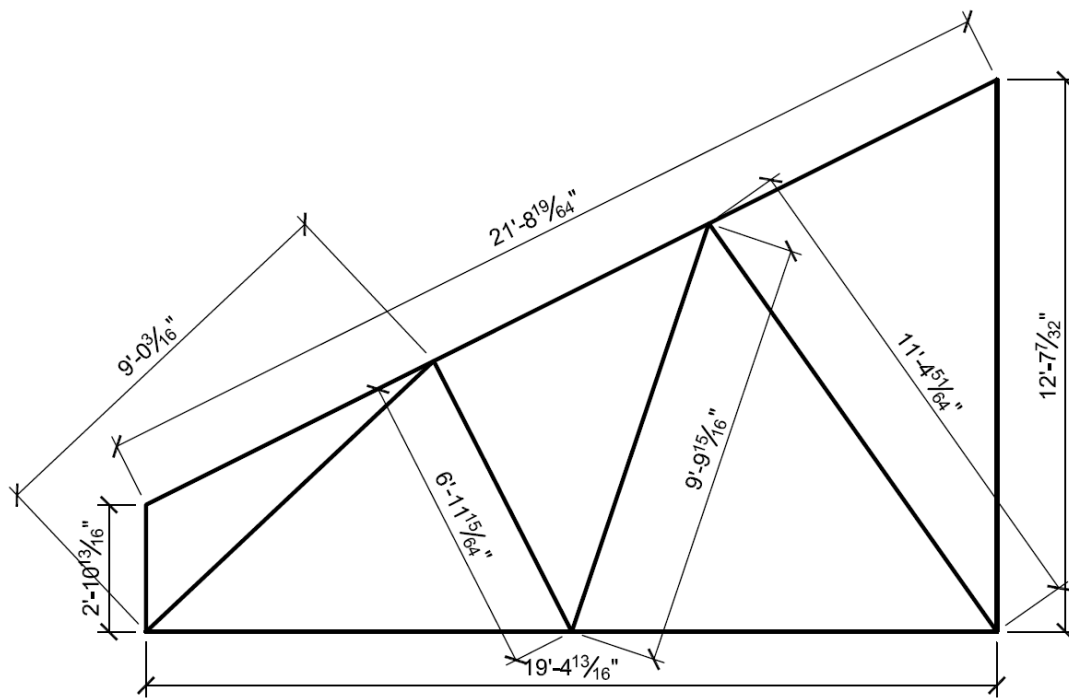

Plate Offsets (X,Y): [5:0-3-11,Edge], [6:Edge,0-2-4], [9:Edge,0-1-8]					
LOADING (psf)	SPACING	CSI	DEFL	PLATES	GRIP
TCLL(roof) 20.0	2-0-0	TC 0.91	in (loc) l/defl L/d	MT20	197/144
Snow (Pf/Pg) 30,8/40.0	Plates Increase 1.15	BC 0.64	Vert(LL) 0.27 6-8 >834 360		
TCDL 10.0	Lumber Increase 1.15	WB 0.61	Vert(TL) -0.42 6-8 >543 240		
BCLL 0.0	Rep Stress Incr YES	(Matrix)	Horz(TL) 0.02 6 n/a n/a		
BCDL 10.0	Code IBC2006/TPI2002			Weight: 103 lb	FT = 10%

LUMBER	BRACING
TOP CHORD 2 X 4 SPF No.2	TOP CHORD Structural wood sheathing directly applied or 2-2-0 oc purlins, except end verticals.
BOT CHORD 2 X 4 SPF No.2	BOT CHORD Rigid ceiling directly applied or 8-7-5 oc bracing.
WEBS 2 X 4 SPF Stud *Except*	WEBS 1 Row at midpt 5-6, 4-6, 3-9
W6: 2 X 4 SPF 2100F 1.8E, W1: 2 X 4 SPF No.2	
REACTIONS (lb/size) 6=971/Mechanical, 9=971/0-5-8 (min. 0-1-9)	
Max Horz 9=510(LC 9)	
Max Uplift 6=-246(LC 10), 9=-92(LC 10)	
Max Grav 6=1181(LC 3), 9=1009(LC 3)	
FORCES (lb) - Max. Comp./Max. Ten. - All forces 250 (lb) or less except when shown.	
TOP CHORD 1-10=-278/121, 3-4=-865/219, 5-6=-354/145, 1-9=-331/133	
BOT CHORD 8-9=-417/778, 7-8=-286/551, 6-7=-286/551	
WEBS 4-8=-111/439, 4-6=-899/285, 3-9=-860/142	



a) List each truss member in a table (B1, B2, T1, T2, W1 to W6) and list the following: size, length, species, grade, density, weight).

b) Calculate the total weight of the truss using the table in (a).

Member	Size	Area (in. ²)	Length (ft.)	Species / Grade	γ	density (pcf)	weight (lb.)	
W1	2x4	5.25	2.91	SPF / #2	0.42	26.2	2.8	
W2	2x4	5.25	9.02	SPF / stud	0.42	26.2	8.6	
W3	2x4	5.25	6.94	SPF / stud	0.42	26.2	6.6	
W4	2x4	5.25	9.83	SPF / stud	0.42	26.2	9.4	
W5	2x4	5.25	11.4	SPF / stud	0.42	26.2	10.9	
W6	2x4	5.25	12.61	SPF / 2100F-1.8	0.46	28.7	13.2	
B1/B2	2x4	5.25	19.41	SPF / #2	0.42	26.2	18.5	
T1/T2	2x4	5.25	21.7	SPF / #2	0.42	26.2	20.7	
$\Sigma =$							90.8	lb.

Plates	l (in.)	w (in.)	t (in.)	vol (in. ³)	γ	density (pcf)	weight (lb.)	
3x6	3	6	0.125	2.25	7.85	490	0.638	
3x4	3	4	0.125	1.5	7.85	490	0.425	
3x6	3	6	0.125	2.25	7.85	490	0.638	
5x5	5	5	0.125	3.125	7.85	490	0.886	
4x5	4	5	0.125	2.5	7.85	490	0.709	
3x4	3	4	0.125	1.5	7.85	490	0.425	
3x4	3	4	0.125	1.5	7.85	490	0.425	
3x4	3	4	0.125	1.5	7.85	490	0.425	
4x7	4	7	0.125	3.5	7.85	490	0.992	
$\Sigma =$							5.563	lb.
$2x =$							11.1	lb.

Total truss wt. =	101.9	lb.
--------------------------	--------------	------------

- c) Draw a free-body diagram of the truss and indicate the uniformly distributed loads to the top and bottom chords in pounds per lineal foot (plf) and indicate the supports.
 d) Calculate the maximum possible reaction using the controlling load case Dead + Snow.

Trib width = 2 ft.

Top chord:

$$w_D = (2)(10) = \mathbf{20\text{plf}}$$

$$w_{Lr} = (2)(20) = \mathbf{40\text{plf}}$$

$$w_S = (2)(30.8) = \mathbf{61.6\text{plf}}$$

Bot. chord:

$$w_D = (2)(10) = \mathbf{20\text{plf}}$$

$$w_D = 20 + 20 = 40 \text{ plf}$$

$$w_S = 61.6 \text{ plf}$$

$R_{\max} =$

$$\frac{(20 + 20 + 61.6)(19.41)}{2} = 986 \text{ lb.}$$

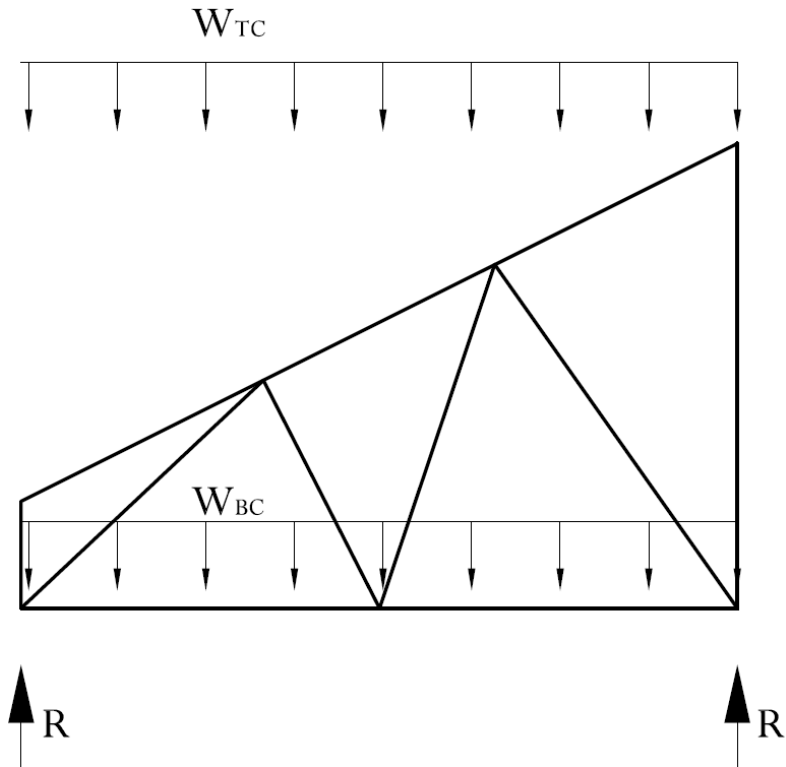

- d) What are the maximum compression loads to W2, W5, and W6 and what is the purpose of the single row of bracing at midpoint?

W2 – 860 lb

W5 – 899lb

W6 – 354 lb

The bracing limits the unbraced length of the members being braced and prevents buckling under compression.

2-11:

Given Loads:

Uniform load, w $D = 500\text{plf}$ $L = 800\text{plf}$ $S = 600\text{plf}$

Beam length = 25 ft.

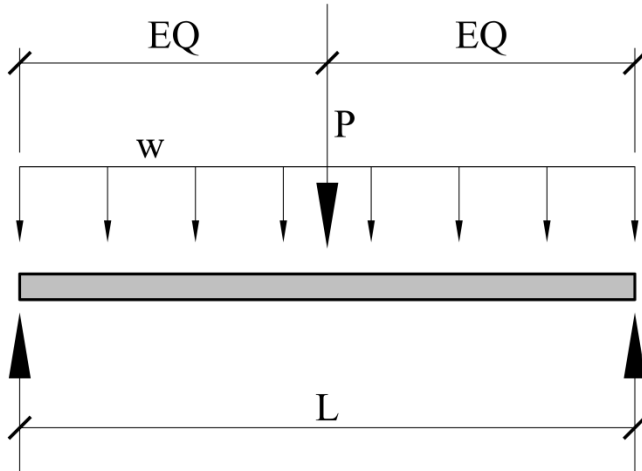
Concentrated Load, P $D = 11\text{k}$ $S = 15\text{k}$ $W = +12\text{k}$ or -12k $E = +8\text{k}$ or -8k 

Do the following:

- Describe a practical framing scenario where these loads could all occur as shown.
- Determine the maximum moment for each individual load effect (D , L , S , W , E)
- Develop a spreadsheet to determine the worst-case bending moments for the code-required load combinations.

- a) Transfer beam that has loads transferred from the roof down to a floor level.

Load Combinations

Uniform Loads

$$w_D := 500 \text{ plf}$$

$$w_L := 800 \text{ plf}$$

$$w_S := 600 \text{ plf}$$

Concentrated Loads

$$P_D := 11 \text{ kips}$$

$$P_S := 15 \text{ kips}$$

$$P_W := 12 \text{ kips}$$

$$P_E := 8 \text{ kips}$$

$$L_B := 25 \text{ ft}$$

$$P_{Wup} := -12 \text{ kips}$$

$$P_{Eup} := -8 \text{ kips}$$

$$M_D := \frac{w_D \cdot L_B^2}{8} + \frac{P_D \cdot L_B}{4} = 108 \cdot \text{ft} \cdot \text{kips}$$

$$M_W := \frac{P_W \cdot L_B}{4} = 75 \cdot \text{ft} \cdot \text{kips}$$

$$M_{Wup} := \frac{P_{Wup} \cdot L_B}{4} = -75 \cdot \text{ft} \cdot \text{kips}$$

$$M_L := \frac{w_L \cdot L_B^2}{8} = 62 \cdot \text{ft} \cdot \text{kips}$$

$$M_E := \frac{P_E \cdot L_B}{4} = 50 \cdot \text{ft} \cdot \text{kips}$$

$$M_{Eup} := \frac{P_{Eup} \cdot L_B}{4} = -50 \cdot \text{ft} \cdot \text{kips}$$

$$M_S := \frac{w_S \cdot L_B^2}{8} + \frac{P_S \cdot L_B}{4} = 141 \cdot \text{ft} \cdot \text{kips}$$

$$LC1 := (1.4 \cdot M_D) = 151 \cdot \text{ft} \cdot \text{kips}$$

$$LC2 := (1.2 \cdot M_D) + (1.6 \cdot M_L) + (0.5 \cdot M_S) = 300 \cdot \text{ft} \cdot \text{kips}$$

$$LC3a := (1.2 \cdot M_D) + (1 \cdot M_L) + (1.6 \cdot M_S) = 417 \cdot \text{ft} \cdot \text{kips}$$

$$LC3b := (1.2 \cdot M_D) + (0.5 \cdot M_W) + (1.6 \cdot M_S) = 392 \cdot \text{ft} \cdot \text{kips}$$

$$LC4 := (1.2 \cdot M_D) + (1.6 \cdot M_W) + (M_L) + (0.5 \cdot M_S) = 382 \cdot \text{ft} \cdot \text{kips}$$

$$LC5 := (1.2 \cdot M_D) + (M_E) + (M_L) + (0.2 \cdot M_S) = 270 \cdot \text{ft} \cdot \text{kips}$$

$$LC6 := (0.9 \cdot M_D) + (1.0 \cdot M_{Wup}) = 22 \cdot \text{ft} \cdot \text{kips}$$

$$LC7 := (0.9 \cdot M_D) + (M_{Eup}) = 47 \cdot \text{ft} \cdot \text{kips}$$

$$M_{\max} := \max(LC1, LC2, LC3a, LC3b, LC4, LC5) = 417 \cdot \text{ft} \cdot \text{kips}$$

$$M_{\maxUp} := \min(LC6, LC7) = 22 \cdot \text{ft} \cdot \text{kips}$$

2-12 (see framing plan)

Assuming a roof dead load of 25 psf and a 25 degree roof slope, determine the following using the IBC factored load combinations. Neglect the rain load, R and assume the snow load, S is zero:

- e. Determine the tributary areas of B1, G1, C1, and W1
- f. The uniform dead and roof live load and the factored loads on B1 in PLF
- g. The uniform dead and roof live load on G1 and the factored loads in PLF
(Assume G1 is uniformly loaded)
- h. The total factored axial load on column C1, in kips
- i. The total factored uniform load on W1 in PLF (assume trib. length of 50 ft.)

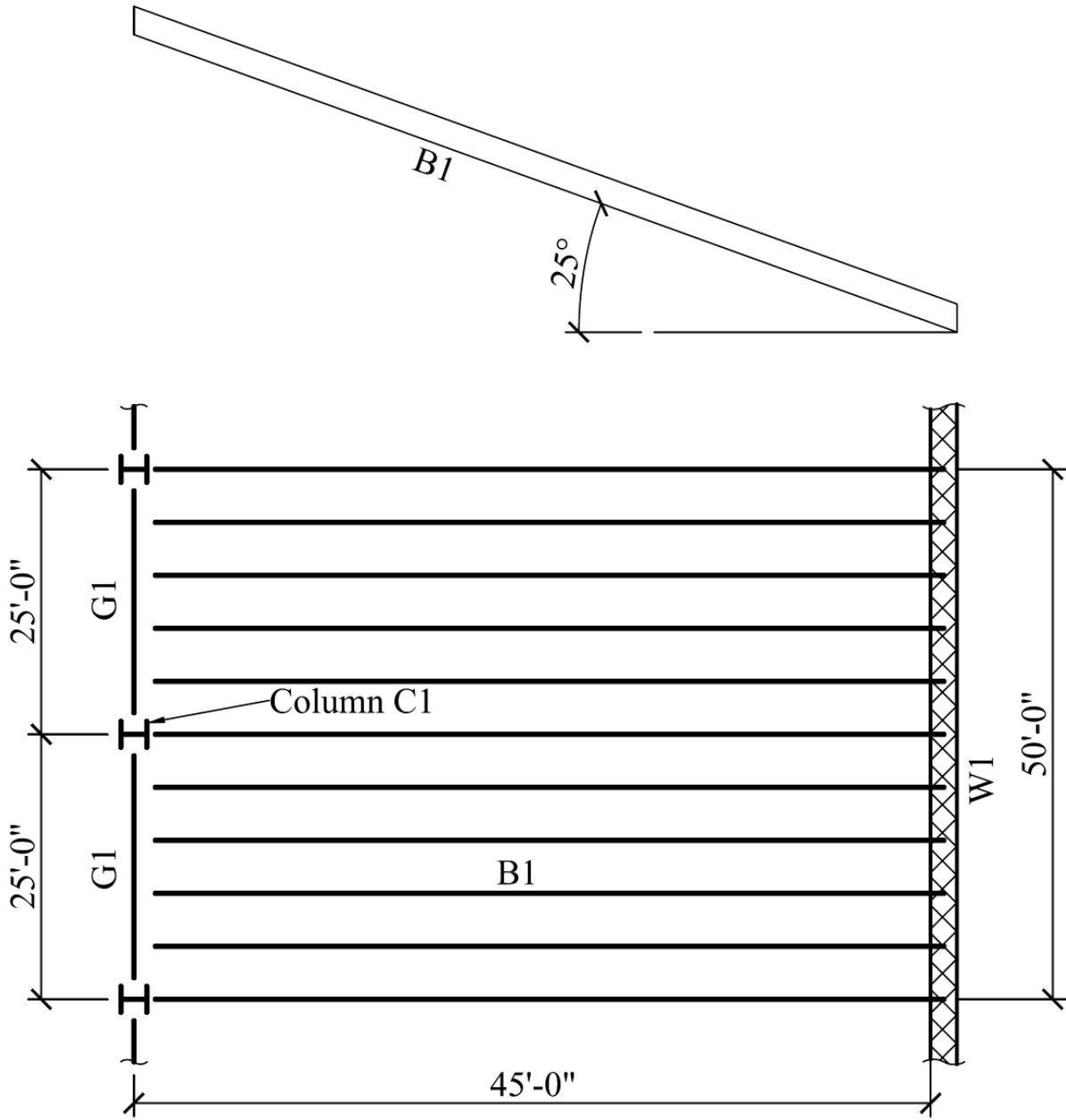

Roof Framing Plan

$$\begin{aligned} \text{Slope} &:= 25 & \underline{F_w} &:= 12 \cdot \tan\left(\text{Slope} \cdot \frac{\pi}{180}\right) = 5.596 & L_B &:= 45\text{ft} & \text{TW}_B &:= 5\text{ft} & D &:= 25\text{psf} \\ R_2 &:= 1.2 - (0.05 \cdot F) = 0.92 & L_G &:= 25\text{ft} & \text{TW}_W &:= 2 \cdot L_G = 50\text{ft} \end{aligned}$$

Part (a):

$$\text{TA}_{B1} := L_B \cdot \text{TW}_B = 225 \text{ft}^2 \quad R_{1B1} := 1.2 - \frac{0.001 \cdot \text{TA}_{B1}}{1\text{ft}^2} = 0.975$$

$$\text{TA}_{G1} := L_G \cdot \frac{L_B}{2} = 562.5 \text{ft}^2 \quad R_{1G1} := 1.2 - \frac{0.001 \cdot \text{TA}_{G1}}{1\text{ft}^2} = 0.638$$

$$\text{TA}_{C1} := L_G \cdot \frac{L_B}{2} = 563 \text{ft}^2 \quad R_{1C1} := 1.2 - \frac{0.001 \cdot \text{TA}_{C1}}{1\text{ft}^2} = 0.638$$

$$\text{TW}_{W1} := \text{TW}_W \cdot \frac{L_B}{2} = 1125 \text{ft}^2 \quad R_{1W1} := 0.6$$

Part (b):

$$L_{rB1} := \max\left[0.6 \cdot 20\text{psf}, (R_{1B1} \cdot R_2 \cdot 20\text{psf})\right] = 17.9 \cdot \text{psf}$$

$$w_{DB1} := \text{TW}_B \cdot D = 125 \cdot \text{plf} \quad w_{LrB1} := \text{TW}_B \cdot L_{rB1} = 90 \cdot \text{plf} \quad w_{uB1} := (1.2 \cdot w_{DB1}) + (1.6 \cdot w_{LrB1}) = 294 \cdot \text{plf}$$

Part (c):

$$L_{rG1} := \max\left[0.6 \cdot 20\text{psf}, (R_{1G1} \cdot R_2 \cdot 20\text{psf})\right] = 12 \cdot \text{psf}$$

$$w_{DG1} := \frac{L_B}{2} \cdot D = 563 \cdot \text{plf} \quad w_{LrG1} := \frac{L_B}{2} \cdot L_{rG1} = 270 \cdot \text{plf} \quad w_{uG1} := (1.2 \cdot w_{DG1}) + (1.6 \cdot w_{LrG1}) = 1107 \cdot \text{plf}$$

Part (d):

$$L_{rC1} := \max\left[0.6 \cdot 20\text{psf}, (R_{1C1} \cdot R_2 \cdot 20\text{psf})\right] = 12 \cdot \text{psf}$$

$$P_{DC1} := \text{TA}_{C1} \cdot D = 14 \cdot \text{kips} \quad P_{LrC1} := \text{TA}_{C1} \cdot L_{rC1} = 7 \cdot \text{kips} \quad P_{uC1} := (1.2 \cdot P_{DC1}) + (1.6 \cdot P_{LrC1}) = 28 \cdot \text{kips}$$

Part (e):

$$L_{rW1} := \max\left[0.6 \cdot 20\text{psf}, (R_{1W1} \cdot R_2 \cdot 20\text{psf})\right] = 12 \cdot \text{psf}$$

$$w_{DW1} := \frac{L_B}{2} \cdot D = 563 \cdot \text{plf} \quad w_{LrW1} := \frac{L_B}{2} \cdot L_{rW1} = 270 \cdot \text{plf} \quad w_{uW1} := (1.2 \cdot w_{DW1}) + (1.6 \cdot w_{LrW1}) = 1107 \cdot \text{plf}$$

2-13. A 3-story building has columns spaced at 25 ft in both orthogonal directions, and is subjected to the roof and floor loads shown below. Using a column load summation table, calculate the cumulative axial loads on a typical interior column. Develop this table using a spreadsheet. Submit a hard copy that is properly formatted with your HW and submit the XLS file by e-mail.

Roof Loads: Dead, D = 20psf Snow, S = 45psf	2nd & 3rd floor loads Dead, D = 60psf Live, L = 100psf
---	--

All other loads are 0

Column Load Table

L1 = 25 ft

L2 = 25 ft

Level	TA (ft. ²)	D (psf)	S (psf)	L (psf)	wu1 (psf)	wu2 (psf)	Pu1 (kips)	Pu2 (kips)	Cumulative		Max. Load (kips)
									Pu1 (kips)	Pu2 (kips)	
Roof	625	20	45	0	46.5	96	29.06	60.00	29.06	60.00	60.00
3rd	625	60	0	100	232	122	145.00	76.25	174.06	136.25	174.06
2nd	625	60	0	100	232	122	145.00	76.25	319.06	212.50	319.06

$$\text{Pu1, wu1} = 1.2D + 1.6L + 0.5S$$

$$\text{Pu2, wu2} = 1.2D + 0.5L + 1.6S$$

2-14 Using only the loads shown and the weight of the concrete footing only ($\gamma_{\text{conc}} = 150\text{pcf}$), determine the required square footing size, $B \times B$ using the appropriate load combination to keep the footing from overturning about point A (i.e. - either load combination 6 or 15 Chapter 2 of the text). Loads shown are service level ($M_w = 0.6W = 45\text{k-ft}$)

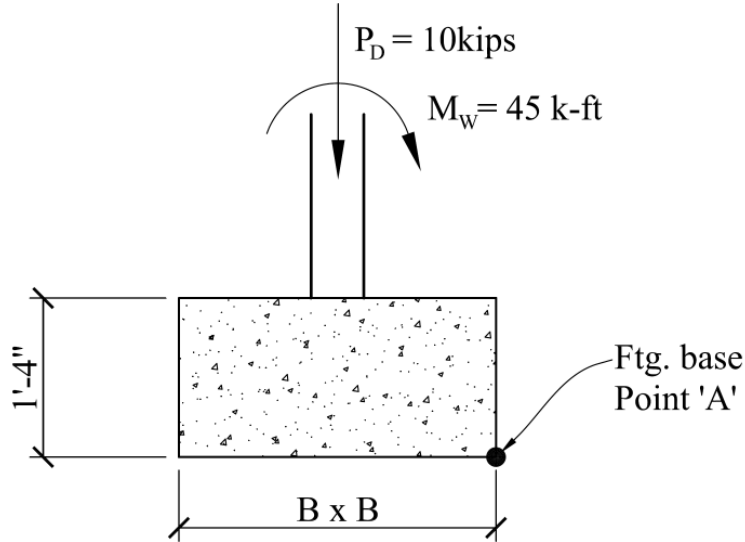

$$P_D := 10\text{kips} \quad M_w := 45\text{ft}\cdot\text{kips} \quad \gamma_{\text{conc}} := 150\text{pcf}$$

$$B := 7.67\text{ft} \quad H := 1.333\text{ft} \quad P_{\text{ftg}} := B \cdot B \cdot H \cdot \gamma_{\text{conc}} = 11.8\cdot\text{kips}$$

Overturning Moment

$$OM := M_w = 45\cdot\text{ft}\cdot\text{kips}$$

Resisting Moment

$$RM := (P_D + P_{\text{ftg}}) \cdot \frac{B}{2} = 83.5\cdot\text{ft}\cdot\text{kips}$$

ASD Load Comb

$$\text{Unity}_{\text{ASD}} := \frac{(0.6 \cdot RM)}{OM} = 1.113$$

LRFD Load Comb

$$\text{Unity}_{\text{LRFD}} := \frac{(0.9 \cdot RM)}{\left(\frac{OM}{0.6}\right)} = 1.002$$

must be greater than 1.0

Use $B=7.28\text{ft}$ for ASD and 7.67ft for LRFD

2-15.

Given:

Location - Massena, NY; elevation is less than 1000 feet

Total roof DL = 25psf

Ignore roof live load; consider load combination 1.2D+1.6S only

Use normal occupancy, temperature, and exposure conditions

Length of B-1, B-2 is 30 ft.

Find:

- Flat roof snow load and sloped roof snow load
- Sliding snow load
- Determine the depth of the balanced snow load and the sliding snow load on B-1 and B-2
- Draw a free-body diagram of B-1 showing the service dead and snow loads in PLF
- Find the factored Moment and Shear in B-1.

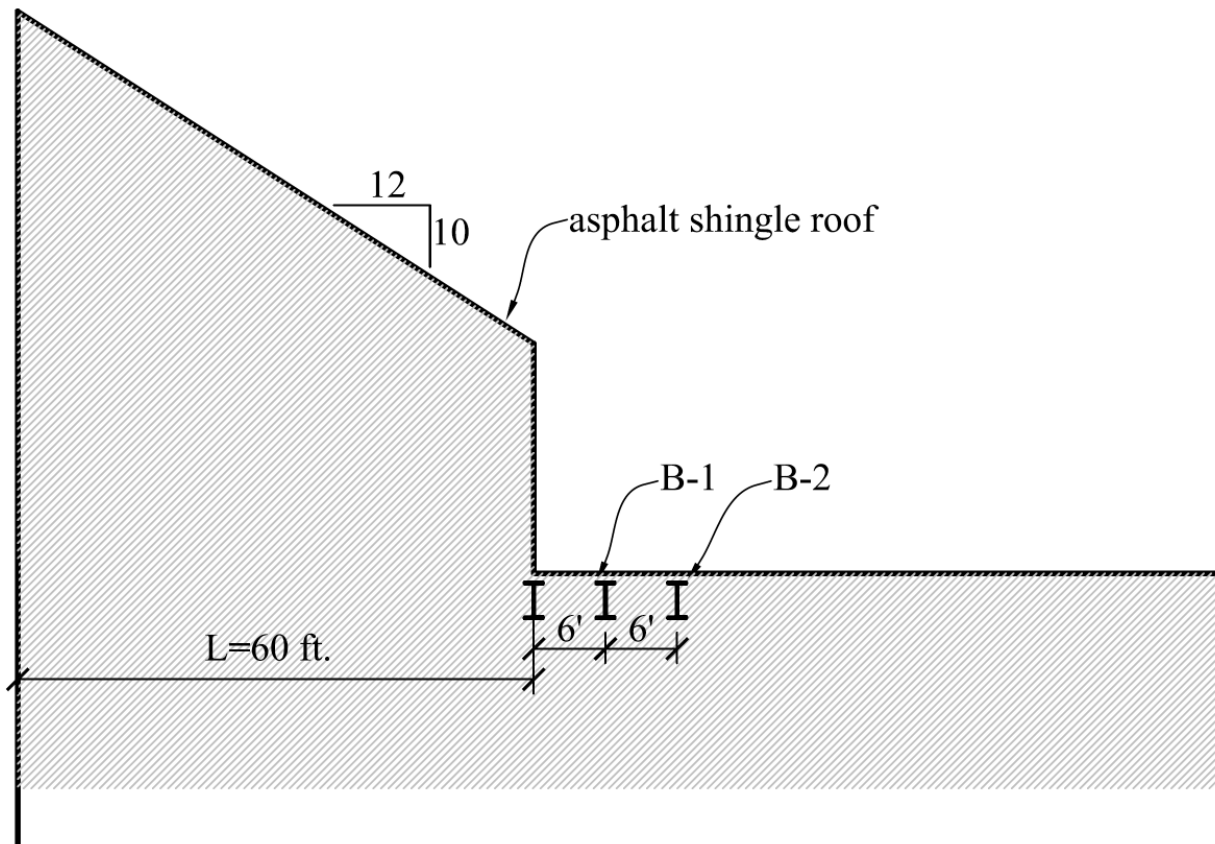

Problem 3-1

$$p_g := 60 \text{ psf} \quad C_e := 1.0 \quad C_t := 1.0 \quad I_s := 1.0 \quad \theta := \text{atan}\left(\frac{10}{12}\right) \cdot \left(\frac{180}{\pi}\right) = 39.806$$

$$C_s := \frac{5}{3} - \frac{\theta}{45} = 0.782 \quad W_{SL} := 60 \text{ ft}$$

$$P_f := 0.7 p_g \cdot C_e \cdot C_t \cdot I_s = 42 \text{ psf} \quad P_s := P_f \cdot C_s = 32.848 \text{ psf} \quad \text{part (a)}$$

$$P_{SL} := \frac{0.4 \cdot P_f \cdot W_{SL}}{15 \text{ ft}} = 67.2 \text{ psf} \quad \text{part (b)}$$

$$\gamma_{\text{snow}} := \frac{0.13}{1 \text{ ft}} \cdot p_g + 14 \text{ pcf} = 21.8 \text{ pcf}$$

$$h_{\text{bal}} := \frac{P_f}{\gamma_{\text{snow}}} = 1.927 \text{ ft} \quad h_{SL} := \frac{P_{SL}}{\gamma_{\text{snow}}} = 3.083 \text{ ft} \quad \text{part (c)}$$

$$L_B := 30 \text{ ft} \quad TW := 6 \text{ ft} \quad D := 25 \text{ psf}$$

$$w_D := TW \cdot D = 150 \text{ plf} \quad w_S := TW \cdot P_f = 252 \text{ plf} \quad w_{SL} := TW \cdot P_{SL} = 403.2 \text{ plf} \quad \text{part (d)}$$

$$w_u := (1.2 \cdot w_D) + [1.6 \cdot (w_S + w_{SL})] = 1228.3 \text{ plf}$$

$$M_u := \frac{w_u \cdot L_B^2}{8} = 138.2 \text{ ft} \cdot \text{kips} \quad V_u := \frac{w_u \cdot L_B}{2} = 18.4 \text{ kips} \quad \text{part (e)}$$

2-16.

Given:

Location - Pottersville, NY; elevation is 1500 feet

Total roof DL = 20psf

Ignore roof live load; consider load combination 1.2D+1.6S only

Use normal occupancy, temperature, and exposure conditions

Find:

- Flat roof snow load
- Depth and width of the leeward drift and windward drifts; which one controls the design of J-1?
- Determine the depth of the balanced snow load and controlling drift snow load
- Draw a free-body diagram of J-1 showing the service dead and snow loads in PLF

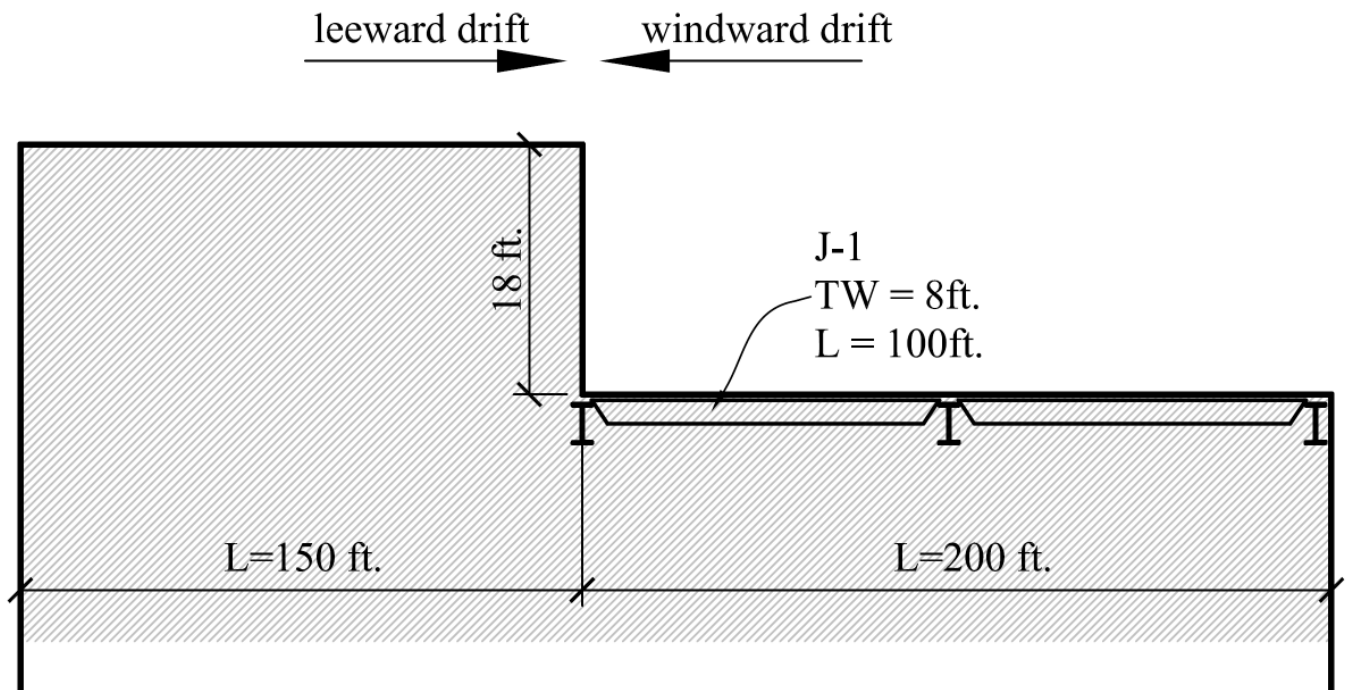

$$p_g := 70\text{psf} + 10\text{psf} = 80\text{psf} \quad C_e := 1.0 \quad C_t := 1.0 \quad I_s := 1.0$$

$$P_f := 0.7p_g \cdot C_e \cdot C_t \cdot I_s = 56\text{psf} \quad \text{part (a)}$$

$$L_{uW} := 200\text{ft} \quad h_{dW} := 0.75\text{ft} \cdot \left[0.43 \cdot \left(\frac{L_{uW}}{1\text{ft}} \right)^{\frac{1}{3}} \cdot \left[\left(\frac{p_g + 10\text{psf}}{1\text{psf}} \right)^{\frac{1}{4}} \right] - 1.5 \right] = 4.684\text{ft}$$

$$L_{uL} := 150\text{ft} \quad h_{dL} := 1\text{ft} \cdot \left[0.43 \cdot \left(\frac{L_{uL}}{1\text{ft}} \right)^{\frac{1}{3}} \cdot \left[\left(\frac{p_g + 10\text{psf}}{1\text{psf}} \right)^{\frac{1}{4}} \right] - 1.5 \right] = 5.537\text{ft} \quad \text{part (b)}$$

$$\gamma_{\text{snow}} := \frac{0.13}{1\text{ft}} \cdot p_g + 14\text{pcf} = 24.4\text{pcf} \quad h_{\text{bal}} := \frac{P_f}{\gamma_{\text{snow}}} = 2.295\text{ft}$$

$$w_W := 4 \cdot h_{dW} = 18.736\text{ft} \quad w_L := 4 \cdot h_{dL} = 22.148\text{ft} \quad \text{part (b)}$$

The Leeward drift will control the design

$$SD := \gamma_{\text{snow}} \cdot h_{dL} = 135.1\text{psf} \quad \text{part (c)}$$

$$L_B := 100\text{ft} \quad TW := 8\text{ft} \quad D := 20\text{psf}$$

$$w_D := TW \cdot D = 160\text{plf} \quad w_S := TW \cdot P_f = 448\text{plf} \quad w_{SD} := TW \cdot SD = 1081\text{plf}$$

$$w_u := (1.2 \cdot w_D) + [1.6 \cdot (w_S + w_{SD})] = 2638\text{plf} \quad \text{part (d)}$$

$$w_{uS} := 1.6 \cdot (w_S + w_{SD}) = 2446\text{plf}$$

Problem 2-16 Part (e)

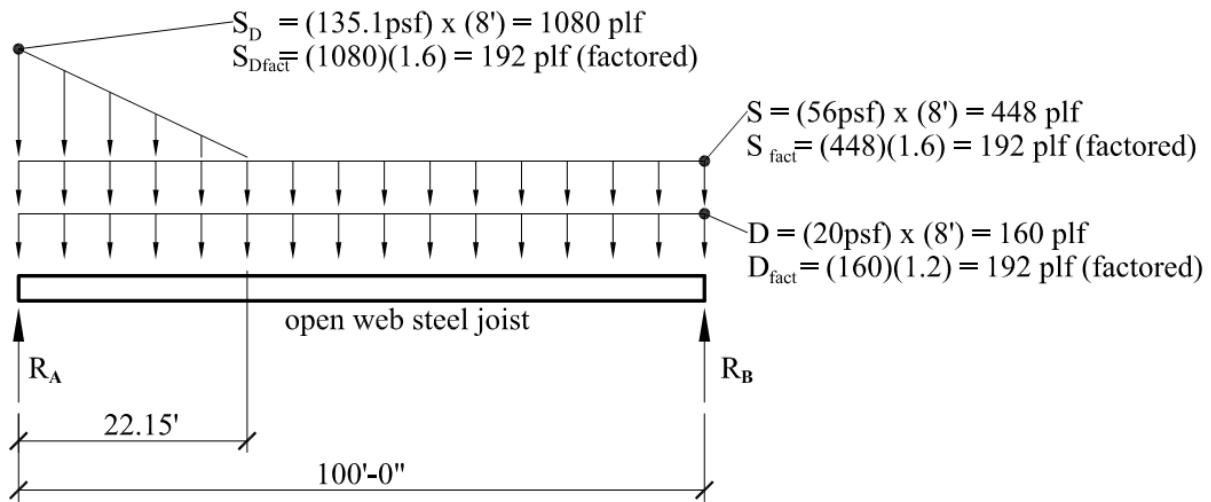
**Factored Reactions and Maximum Moment:**

$$R_A = 63.18 \text{ kips}$$

$$R_B = 46.85 \text{ kips}$$

$$M_{u, \text{max}} = 1207.6 \text{ ft-kips (occurs at 51.55 ft from B)}$$